

DD-2512-HL/10XX

Call 800-321-7800 or visit us online at www.nookindustries.com to configure and order your DD-2512-HL/10XX today!

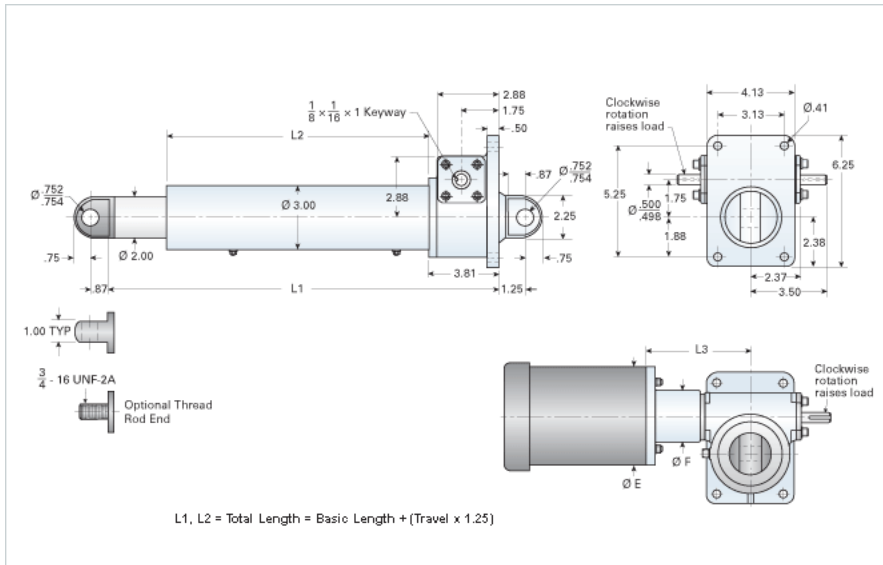

Performance Specifications

Travel Rate [in/min]	144
Dynamic Capacity [lb]	1500
Rated Life [in]	2910000
Motor Horse Power [hp]	1
Maximum Rod Reaction Torque [in-lb]	265
Std. Brake Torque [ft-lb]	0.25
Approximate Stopping Distance No Load [in]	0.35
Approximate Stopping Distance Full Load [in]	6.00

Details

Gear Ratio	12:1
Input Turns Per Inch Of Travel	12
Torque To Raise 1 lb. [in-lb]	0.0244
Max Capacity [lb]	5000
Max HP [hp]	1.5

Weight

Basic Weight [lb]	33
Per Inch of Travel [lb]	1.05

Tube Dimensions

L1 Basic Length [in]	12.44
L2 Basic Length [in]	7.13

NEMA 42 Dimensions

L3 [in]	-
E [in]	-
F [in]	-

NEMA 48 Dimensions

L3 [in]	-
E [in]	-
F [in]	-

NEMA 56C Dimensions

L3 [in]	6.25
E [in]	6.62
F [in]	3.50

NEMA 182TC Dimensions

L3 [in]	-
E [in]	-
F [in]	-

NEMA 184TC Dimensions

L3 [in]	-
E [in]	-
F [in]	-

NEMA 213TC Dimensions

L3 [in]	-
E [in]	-
F [in]	-