

DSSZ 160 Extended Carriage

Call 800-321-7800 or visit us online at www.nookindustries.com to configure and order your DSSZ 160 Extended Carriage today!

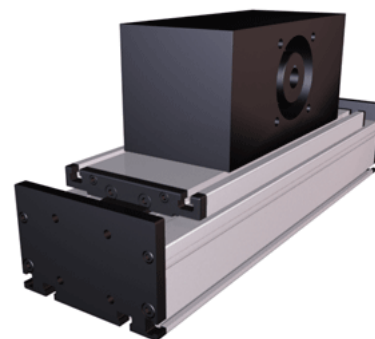
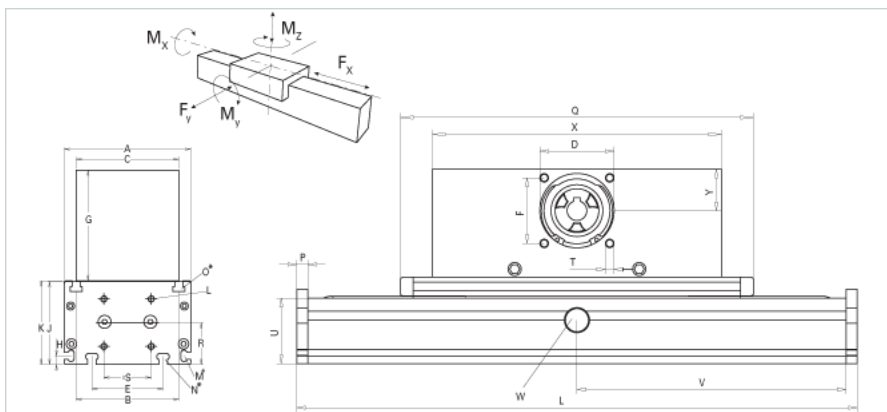

Details	
Size	160
Belt	8M50
mm/Rev	256
Number of Teeth	32
Pully Diameter [mm]	81.5
Dimensions	
Basic Length L [mm]	410
A [mm]	160
B [mm]	130
C [mm]	130
D [mm]	90
E [mm]	90
F [mm]	80
G [mm]	140
H [mm]	11
J [mm]	105
K [mm]	106
L [mm]	
M	M6
N	M8
O	M8
P [mm]	12
Q [mm]	370
R [mm]	53
S [mm]	60
T	M10
U [mm]	80
X [mm]	270
Y [mm]	60
Shaft Diameter and Length [mm]	22 x 45
Key	6x6x40
Speed	
Speed Maximum [m/s]	5
Forces and Torques	
Fx [N] 10000 km	3800
Fy [N] 10000 km	1775
Fz [N] 10000 km	4189
Mx [Nm] 10000 km	224
My [Nm] 10000 km	225
Mz [Nm] 10000 km	238
Fx [N] 5000 km	4000
Fy [N] 5000 km	2236
Fz [N] 5000 km	5278
Mx [Nm] 5000 km	282
My [Nm] 5000 km	283
Mz [Nm] 5000 km	300
No-load torque [Nm]	1.8
Tensile force 0.2 sec [N]	4300
Tensile force permanent [N]	4000
Geometrical moments of inertia of aluminum profile	
Elastic modulus [N/mm ²]	70000
Ix [mm ⁴]	2130000

ly [mm ⁴]	1230000
Weight	
Additional Weight per 100 mm [kg]	1.80
Basic Weight [kg]	27.8