

## ELZU 100 X&Y-Axis WAC

Call 800-321-7800 or visit us online at [www.nookindustries.com](http://www.nookindustries.com) to configure and order your ELZU 100 X&Y-Axis WAC today!

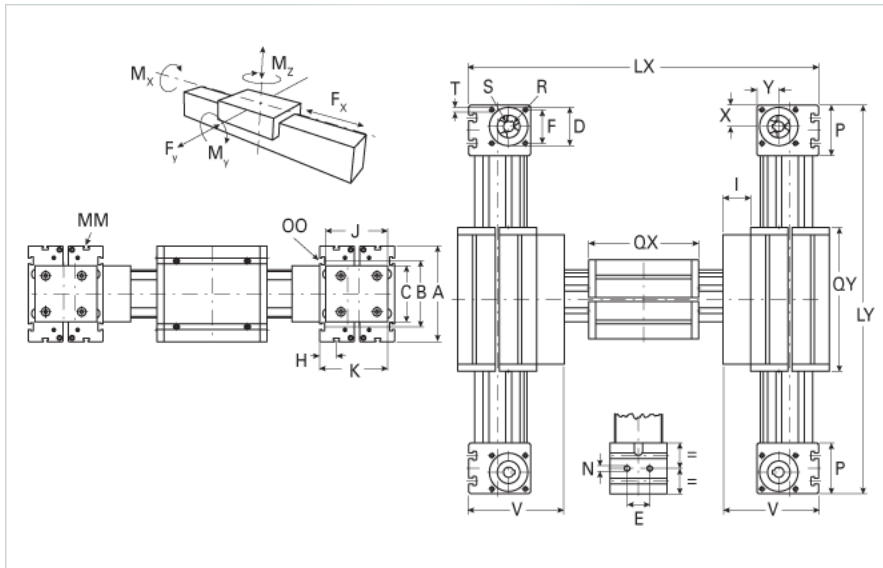
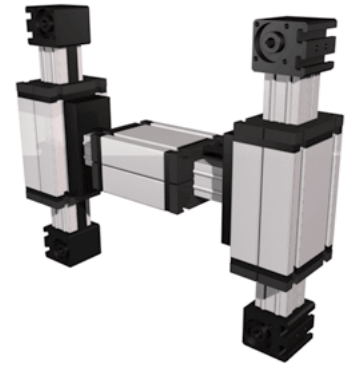

### Details

Size	100
Belt	8M50
mm/Rev	256
Number of Teeth	32
Pully Diameter [mm]	81.5

### Dimensions

Basic length Lx [mm]	774
Basic length Ly [mm]	606
A [mm]	230
B [mm]	155
C [mm]	130
D [mm]	90
E [mm]	50
F [mm]	80
G [mm]	-
H [mm]	30
I [mm]	69
J [mm]	135
K [mm]	154
MM	M10
N	M12
OO	M12
P [mm]	110
Qx [mm]	316
Qy [mm]	376
T	M10
V [mm]	223
X [mm]	50
Y [mm]	50
Shaft Diameter and Length [mm]	22 x 45
Key	6x6x40

### Speed

Speed Maximum [m/s]	8
---------------------	---

### Forces and Torques

No-load torque [Nm]	2.6
Tensile force 0.2 sec [N]	4000
Tensile force permanent [N]	3600
Fx dynamic [N]	3800
Fy dynamic [N]	6500
Fz dynamic [N]	2200
Mx dynamic [Nm]	230
My dynamic [Nm]	270
Mz dynamic [Nm]	500
Fx static [N]	4000
Fy static [N]	8000
Fz static [N]	3600

Mx static [Nm]	300
My static [Nm]	400
Mz static [Nm]	750
<b>Geometrical moments of inertia of aluminum profile</b>	
Elastic modulus [N/mm <sup>2</sup> ]	70000
Ix [mm <sup>4</sup> ]	4440000
Iy [mm <sup>4</sup> ]	4480000
<b>Weight</b>	
Additional Weight per 100 mm [kg]	1.40
Basic Weight [kg]	47.3