

ELZU 60 X-Axis WAC

Call 800-321-7800 or visit us online at www.nookindustries.com to configure and order your ELZU 60 X-Axis WAC today!

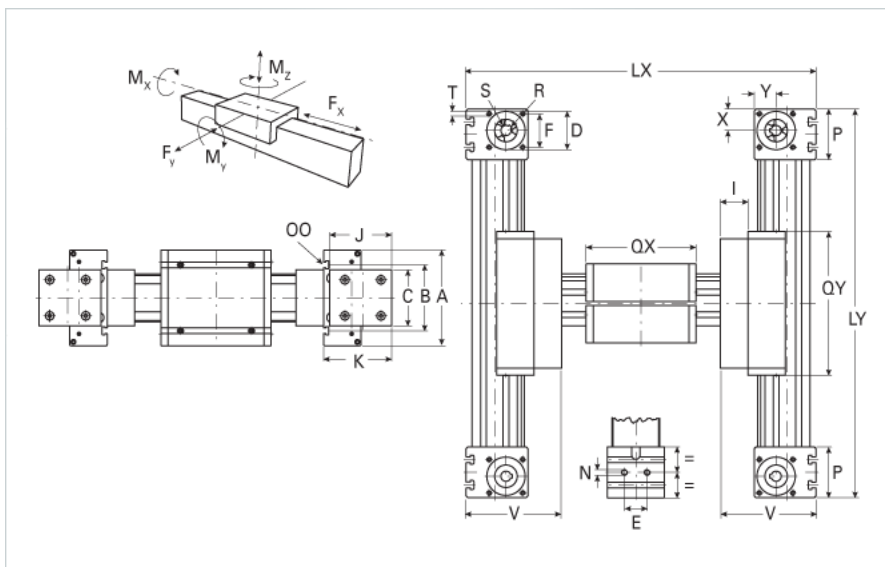
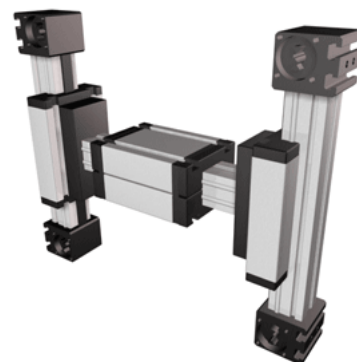

Details	
Size	60
Belt	5M25
mm/Rev	130
Number of Teeth	26
Pully Diameter [mm]	41.4
Dimensions	
Basic length Lx [mm]	442
Basic length Ly [mm]	330
A [mm]	144
B [mm]	96
C [mm]	80
D [mm]	47
E [mm]	30
F [mm]	42
G [mm]	-
H [mm]	-
I [mm]	33
J [mm]	82
K [mm]	90
MM	-
N	M8
OO	M8
P [mm]	59
Qx [mm]	184
Qy [mm]	208
T	M6
V [mm]	123
X [mm]	26
Y [mm]	26
Shaft Diameter and Length [mm]	14 x 35
Key	5x5x28
Speed	
Speed Maximum [m/s]	5
Forces and Torques	
No-load torque [Nm]	1.2
Tensile force 0.2 sec [N]	1000
Tensile force permanent [N]	900
Fx dynamic [N]	800
Fy dynamic [N]	2000
Fz dynamic [N]	1100
Mx dynamic [Nm]	43
My dynamic [Nm]	70
Mz dynamic [Nm]	100
Fx static [N]	894
Fy static [N]	3000
Fz static [N]	1700

Mx static [Nm]	67
My static [Nm]	90
Mz static [Nm]	120
Geometrical moments of inertia of aluminum profile	
Elastic modulus [N/mm ²]	70000
Ix [mm ⁴]	679000
Iy [mm ⁴]	697000
Weight	
Additional Weight per 100 mm [kg]	0.62
Basic Weight [kg]	14.7