

ELSD 80 WAC Extended Carriage

Call 800-321-7800 or visit us online at www.nookindustries.com to configure and order your ELSD 80 WAC Extended Carriage today!

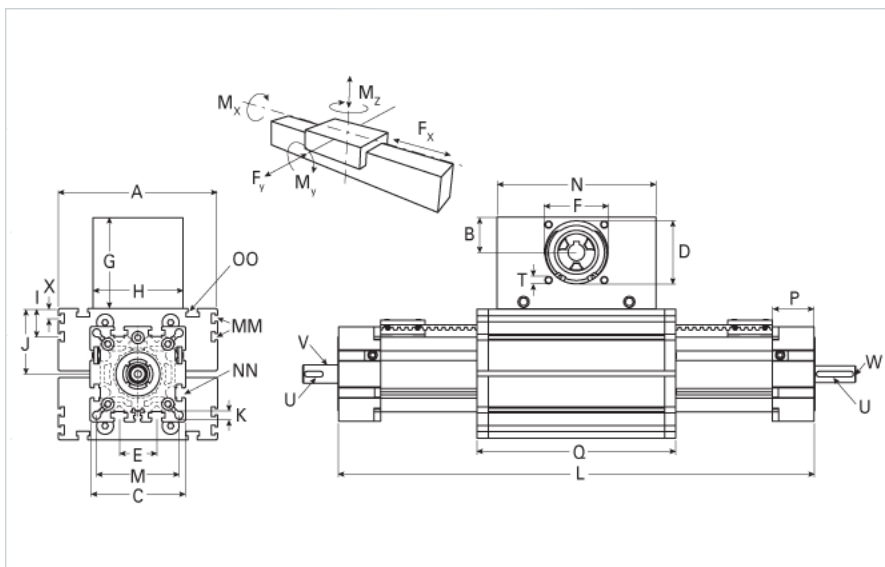
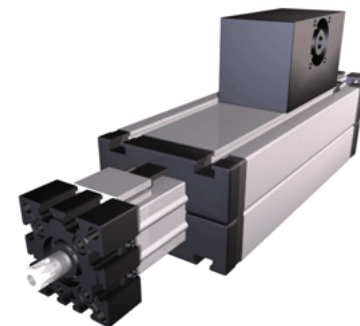

Details	
Size	80
Belt	8M30
mm/Rev	192
Number of Teeth	24
Pully Diameter [mm]	61.1
Dimensions	
Basic Length L [mm]	541
A [mm]	170
B [mm]	39
C [mm]	102
D [mm]	68
E [mm]	40
F [mm]	60
G [mm]	100
H [mm]	100
I [mm]	30
J [mm]	70
K [mm]	8.8
M [mm]	88
MM	M6
N [mm]	180
NN	M10
OO	M10
P [mm]	45
Q [mm]	395
T	M8
X [mm]	10
V (Z Drive End) [mm]	18 x 30
U (Z Drive End) [mm]	6x6x20
V (Z Load End) [mm]	20 x 30
U (Z Load End) [mm]	6x6x20
W (Z Load End) [mm]	M10x20
Shaft Diameter and Length [mm]	18 x 45
Key	6x6x40
Speed	
Speed Maximum [m/s]	6
Forces and Torques	
No-load torque Stiction torque Mr [Nm]	0.1
No-load torque [Nm]	1.1
Tensile force 0.2 sec [N]	2090
Tensile force permanent [N]	1900
Fd [N]	250
Mr [Nm]	20
Fx dynamic [N]	1800
Fy dynamic [N]	2000
Fz dynamic [N]	1100

Mx dynamic [Nm]	55
My dynamic [Nm]	80
Mz dynamic [Nm]	120
Fx static [N]	1900
Fy static [N]	3000
Fz static [N]	1700
Mx static [Nm]	90
My static [Nm]	110
Mz static [Nm]	150
Geometrical moments of inertia of aluminum profile	
Elastic modulus [N/mm ²]	70000
Ix [mm ⁴]	1899000
Iy [mm ⁴]	1897000
Weight	
Additional Weight per 100 mm [kg]	1.30
Basic Weight [kg]	12.5