

## ELZZ 125 WAC

Call 800-321-7800 or visit us online at [www.nookindustries.com](http://www.nookindustries.com) to configure and order your ELZZ 125 WAC today!

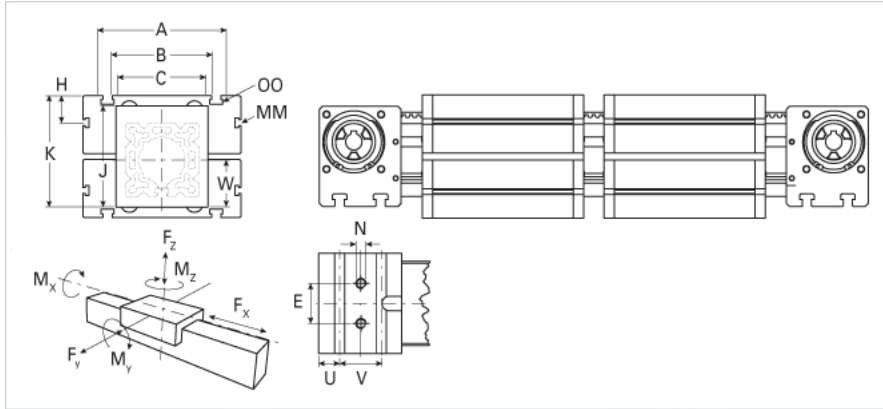
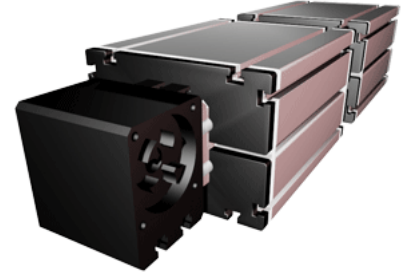

### Details

Size	125
Belt	8M30
mm/Rev	304
Number of Teeth	38
Pully Diameter [mm]	96.8

### Dimensions

Basic Length L [mm]	1038
A [mm]	295
B [mm]	200
C [mm]	160
D [mm]	110
E [mm]	60
F [mm]	100
G [mm]	-
H [mm]	30
J [mm]	167
K [mm]	191
MM	M10
N	M12
OO	M12
P [mm]	130
Q [mm]	389
T	M10
U [mm]	40
V [mm]	50
W [mm]	82
X [mm]	60
Y [mm]	60

### Speed

Speed Maximum [m/s]	10
---------------------	----

### Forces and Torques

No-load torque [Nm]	1.8
Tensile force 0.2 sec [N]	2090
Tensile force permanent [N]	1900
Fx dynamic [N]	1800
Fy dynamic [N]	9000
Fz dynamic [N]	4500
Mx dynamic [Nm]	450
My dynamic [Nm]	600
Mz dynamic [Nm]	1150
Fx static [N]	1900
Fy static [N]	12000
Fz static [N]	6000
Mx static [Nm]	600
My static [Nm]	750
Mz static [Nm]	1350

### Geometrical moments of inertia of aluminum profile

Elastic modulus [N/mm <sup>2</sup> ]	70000
Ix [mm <sup>4</sup> ]	10150000
Iy [mm <sup>4</sup> ]	10150000

### Weight

Additional Weight per 100 mm [kg]	2.10
-----------------------------------	------

