

## ELK 80S WAC

Call 800-321-7800 or visit us online at [www.nookindustries.com](http://www.nookindustries.com) to configure and order your ELK 80S WAC today!

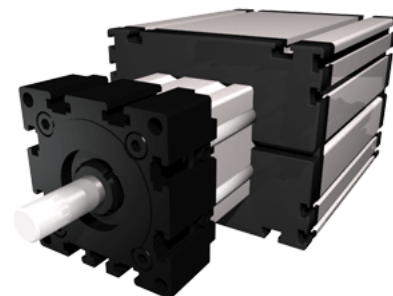
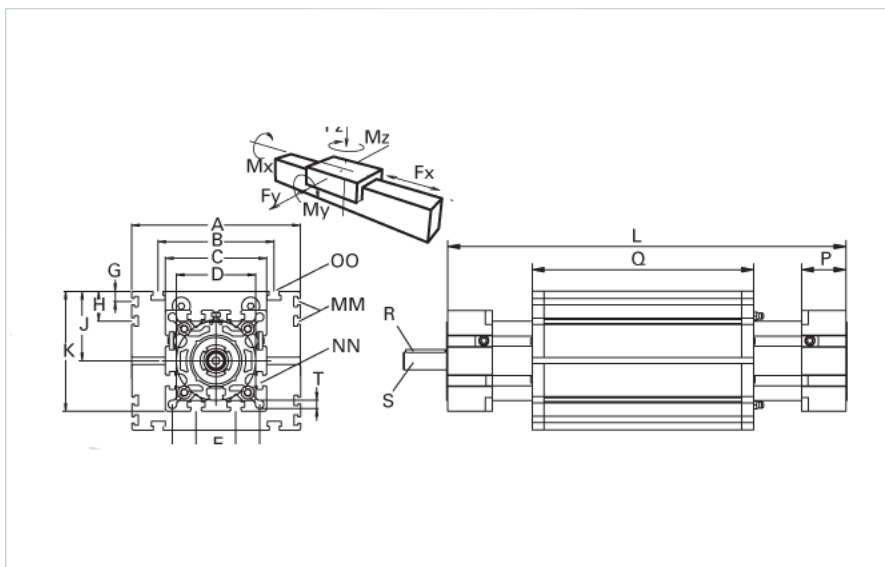

<b>Details</b>	
Size	80S
Screw Options	32x5/25x25/32x10
Screw Type	Ball Screw
<b>Dimensions</b>	
Basic Length L [mm]	325
A [mm]	190
B [mm]	126
C [mm]	102
D [mm]	80x1
E [mm]	40
F [mm]	88
G [mm]	12.5
H [mm]	30
J [mm]	71
K [mm]	122
MM	M6
NN	M10
OO	M8
P [mm]	45
Q [mm]	234
R [mm]	6x6x40
S Diameter x Length [mm]	18x45
T-Diameter [mm]	8.5
<b>Forces and Torques</b>	
Fx dynamic [N]	4000
Fy dynamic [N]	3600
Fz dynamic [N]	1800
Mx dynamic [Nm]	140
My dynamic [Nm]	230
Mz dynamic [Nm]	220
Fx static [N]	5000
Fy static [N]	4600
Fz static [N]	3000
Mx static [Nm]	170
My static [Nm]	270
Mz static [Nm]	300
<b>Geometrical moments of inertia of aluminum profile</b>	
Elastic modulus [N/mm <sup>2</sup> ]	70000
Ix [mm <sup>4</sup> ]	1899000
Iy [mm <sup>4</sup> ]	1897000
<b>Weight</b>	
Additional Weight per 100 mm [kg]	1.48
Basic Weight [kg]	11.0