

## EGT 60 WAC

Call 800-321-7800 or visit us online at [www.nookindustries.com](http://www.nookindustries.com) to configure and order your EGT 60 WAC today!

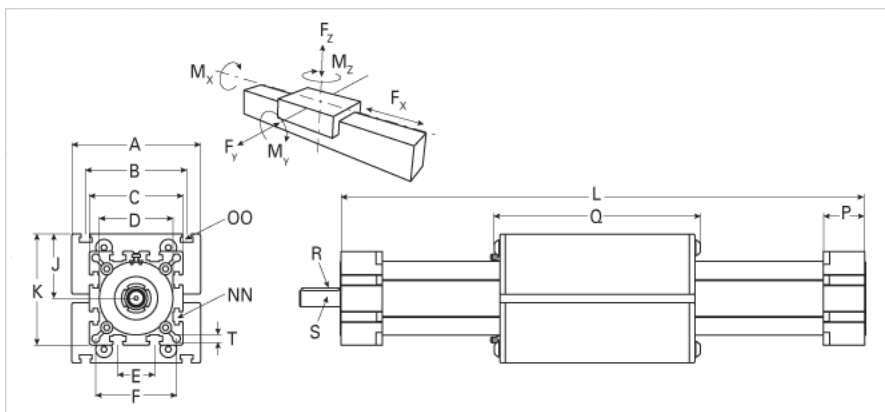
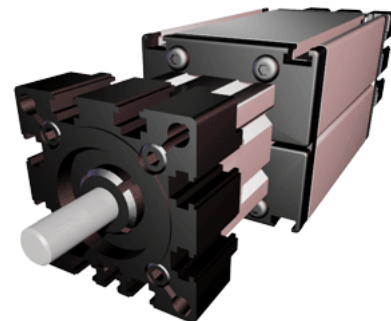

Details	
Size	60
Screw Options	24x5/24x10
Screw Type	Trapezoidal
Dimensions	
Basic Length L [mm]	253
A [mm]	100
B [mm]	80
C [mm]	82
D [mm]	62x1
E [mm]	30
F [mm]	69
H [mm]	-
J [mm]	49
K [mm]	90
MM [mm]	-
NN [mm]	M8
OO [mm]	M8
P [mm]	35
Q [mm]	181
R [mm]	5x5x28
S Diameter x Length [mm]	14x35
T-Diameter [mm]	8.5
Forces and Torques	
No Load Torque [Nm]	0.8
Fx dynamic [N]	2000
Fy dynamic [N]	450
Fz dynamic [N]	675
Mx dynamic [Nm]	30
My dynamic [Nm]	70
Mz dynamic [Nm]	50
Fx static [N]	2500
Fy static [N]	500
Fz static [N]	750
Mx static [Nm]	33
My static [Nm]	77
Mz static [Nm]	55
Geometrical moments of inertia of aluminum profile	
Elastic modulus [N/mm <sup>2</sup> ]	70000
Ix [mm <sup>4</sup> ]	565000
Iy [mm <sup>4</sup> ]	612000
Weight	
Additional Weight per 100 mm [kg]	0.67
Basic Weight [kg]	4.0