

NU20SER Assembly

Call 800-321-7800 or visit us online at www.nookindustries.com to configure and order your NU20SER Assembly today!

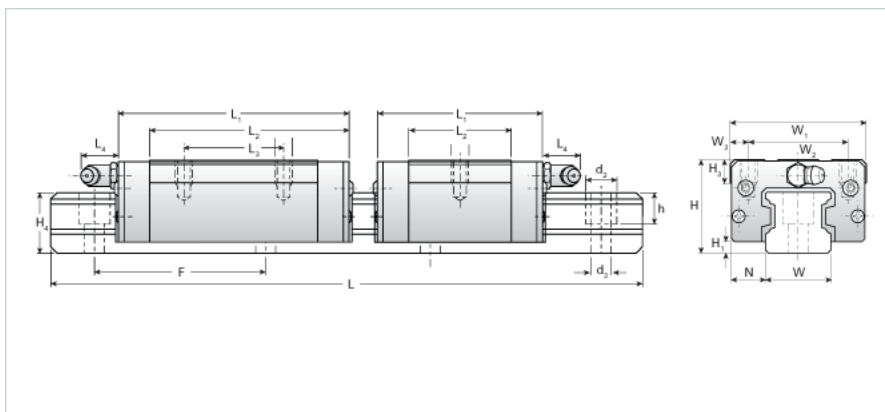

Dimensions	
H [mm]	28
H1 [mm]	4
N [mm]	11.0
Metric Profile Rail	
Details	
Size [mm]	20
Type	Compact
Dimensions	
d2 [mm]	9.5
d3 [mm]	6
h [mm]	12
H4 [mm]	19.5
F [mm]	60
W [mm]	20
Maximum Length [mm]	3000
Weight	
Weights-Rail [kg/m]	2.5
Metric Runner Block, Medium Load, Compact Type, 2 Tapped Holes	
Details	
Size [mm]	20
Dimensions	
L1 [mm]	52
L2 [mm]	30
L4 [mm]	0
M1 x l	M5X7
H3 [mm]	7.5
W1 [mm]	42
W2 [mm]	32
W3 [mm]	5
Forces and Torques	
Basic Load Ratings C [kN]	9.12
Basic Load Ratings C [lbf]	2050
Basic Load Ratings C0 [kN]	12.94
Basic Load Ratings C0 [lbf]	2909
Static Moment Ratings-Ma [kN-m]	0.05
Static Moment Ratings-Ma [lb-in]	434
Static Moment Ratings-Mb [kN-m]	0.05
Static Moment Ratings-Mb [lb-in]	434
Static Moment Ratings-Mc [kN-m]	0.15
Static Moment Ratings-Mc [lb-in]	1302
Weight	
Weight-Block [kg]	0.16
Grease Fitting	
Grease Fitting Part Number	NAS516-1A