

NU20ER

Call 800-321-7800 or visit us online at www.nookindustries.com to configure and order your NU20ER today!

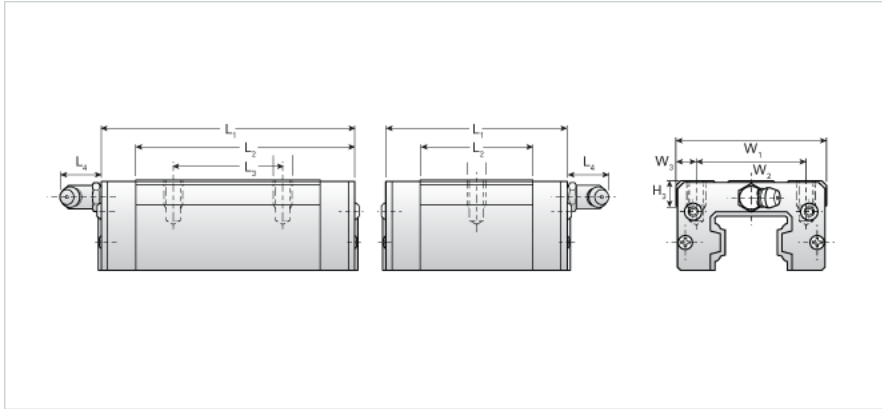
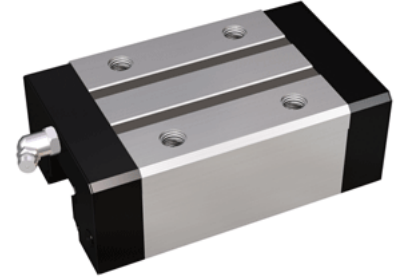

Details	
Size [mm]	20
Dimensions	
L1 [mm]	72
L2 [mm]	50
L3 [mm]	32
L4 [mm]	0
H3 [mm]	7.5
M1 x l	M5X7
W1 [mm]	42
W2 [mm]	32
W3 [mm]	5
Forces and Torques	
Basic Load Ratings C [kN]	13.92
Basic Load Ratings C [lbf]	3130
Basic Load Ratings C0 [kN]	23.82
Basic Load Ratings C0 [lbf]	5356
Static Moment Ratings-Ma [kN-m]	0.16
Static Moment Ratings-Ma [lb-in]	1389
Static Moment Ratings-Mb [kN-m]	0.16
Static Moment Ratings-Mb [lb-in]	1389
Static Moment Ratings-Mc [kN-m]	0.26
Static Moment Ratings-Mc [lb-in]	2344
Weight	
Weight-Block [kg]	0.27
Grease Fitting	
Grease Fitting Part Number	NAS516-1A