

ELFZ 80S

Call 800-321-7800 or visit us online at www.nookindustries.com to configure and order your ELFZ 80S today!

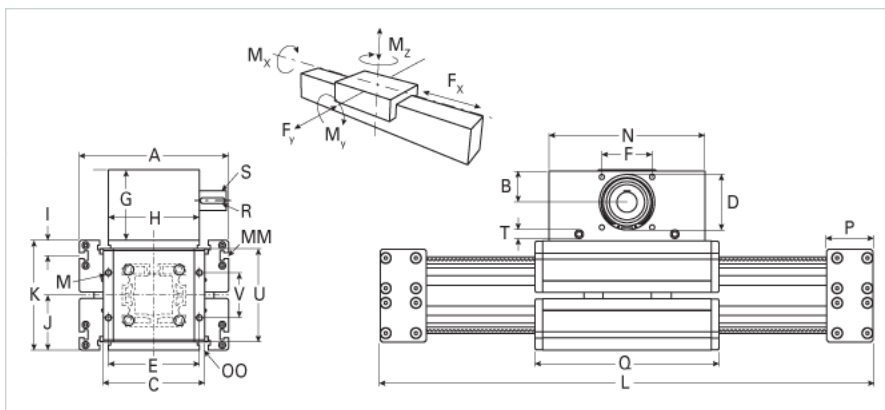
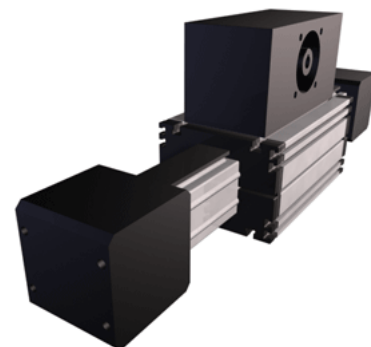

Details	
Size	80S
Belt	8M50
mm/Rev	128
Number of Teeth	32
Dimensions	
Basic Length L [mm]	580
A [mm]	190
B [mm]	60
C [mm]	126
D [mm]	90
E [mm]	134
F [mm]	80
G [mm]	139
H [mm]	130
I [mm]	12.5
J [mm]	71
K [mm]	142
M	M10
MM	M6
N [mm]	270
OO [mm]	M8
P [mm]	130
Q [mm]	315
R [mm]	8x7x40
S [mm]	30x45
T	M10
U [mm]	130
V [mm]	70
Shaft Diameter and Length [mm]	30 x 45
Key	8x7x40
Speed	
Speed Maximum [m/s]	4
Forces and Torques	
Drive Torque Maximum [Nm]	120
No-load torque [Nm]	1.5
Mz dynamic [Nm]	440
Mz static [Nm]	600
Fx dynamic [N]	5400
Fy dynamic [N]	7200
Fz dynamic [N]	3600
Mx dynamic [Nm]	280
My dynamic [Nm]	460
Fx static [N]	6200
Fy static [N]	9200
Fz static [N]	6000
Mx static [Nm]	340
My static [Nm]	540
Geometrical moments of inertia of aluminum profile	
Elastic modulus [N/mm ²]	70000
Ix [mm ⁴]	1890000
Iy [mm ⁴]	1890000
Weight	

Additional Weight per 100 mm [kg]	1.20
Basic Weight [kg]	51.0
Values for Calculating Inertias	
Pulley Material - Drive Pulley (x5)	Steel
Pulley Material - Idler Pulleys (x2)	Plastic
Pulley Diameter [mm]	81.48
Effective Pulley Width [mm]	130
Belt Weight [kg/m]	0.256
Standard Carriage Weight [kg]	11.04
No-load torque [Nm]	1.5
Friction Coefficient	0.01