

HEAVY LOAD TYPE

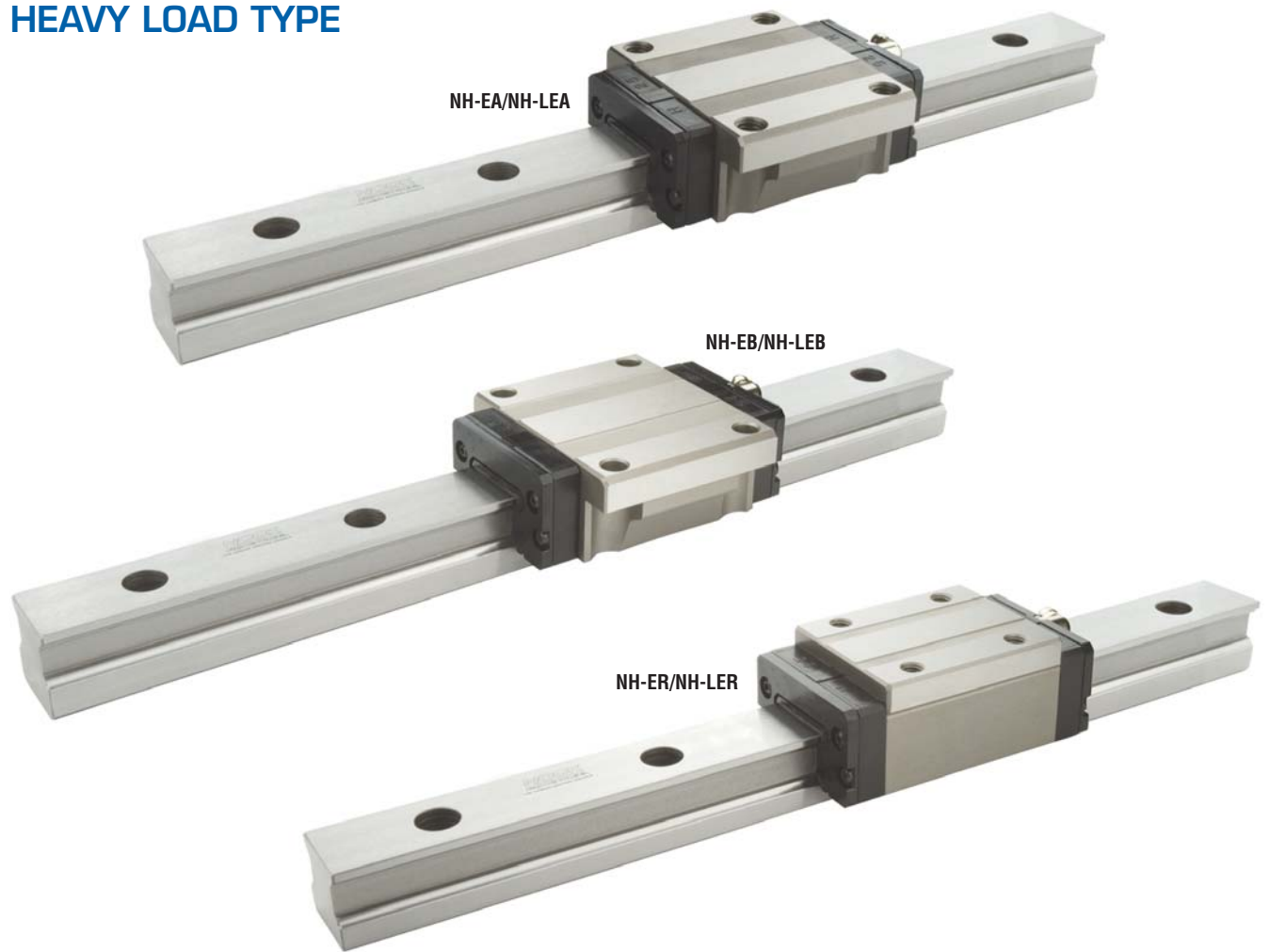

SELECTION OF ULTRA HEAVY AND HEAVY LOAD TYPE

CLASSIFICATION	ULTRA HEAVY LOAD TYPE			HEAVY LOAD TYPE		
MODEL TYPE	NH-LEA	NH-LEB	NH-LER	NH-EA	NH-EB	NH-ER
Mounting Direction						
Main Features	Ultra heavy load type with long runner blocks			Flange type heavy load type		Narrow width heavy load type
Permissible speed (m/min.)	120	120	120	120	120	120
Accuracy	C001-C7	C001-C7	C001-C7	C001-C7	C001-C7	C001-C7
Preload	T-T3	T-T3	T-T3	T-T3	T-T3	T-T3
Vibration Behavior	○	○	○	○	○	○
Noise	○	○	○	○	○	○

See unit conversion on page 48

○ Low

● Very Low

FEATURES

NOOK Profile Rail Design

NOOK Ultra Heavy Load Type Runner Blocks maintain circulation of the balls by a retainer and end cap. The four rows of balls on the inner runner block are arranged in two rows on either side facing each other and contacting at a 45° angle. As the load is transmitted the balls contact the rail at two points at an inclusive angle of 90°. In turn, the contact with the outer track is the same, making a square load force configuration.

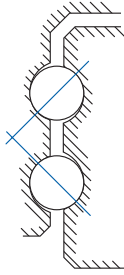

Equal Load in Four Directions

The shape of NOOK runner blocks have an equal rated load capacity in any direction. Equal rigidity is therefore obtained in any of the four loading directions making NOOK runner blocks ideal for single or combination loads.

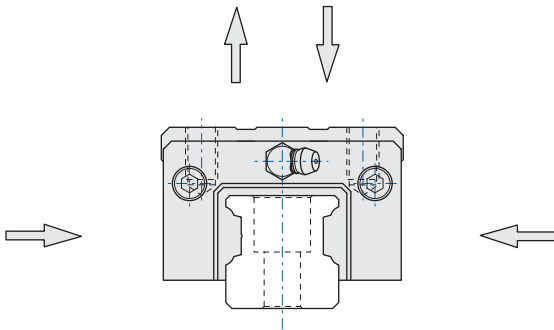

Mounting Error Absorption and Rolling Moment Rigidity

NOOK runner blocks are designed to absorb some of the mounting inaccuracies without any significant increase in the sliding friction.

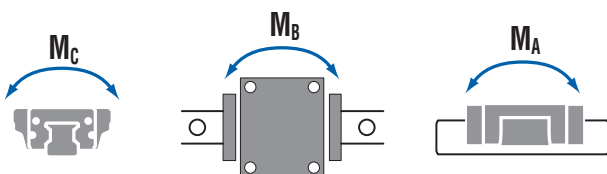

Error Allowance in the Parallelism Between Two Rails—Horizontal Plane

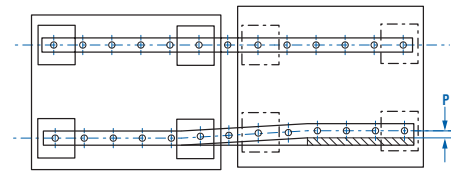

Permissible Tolerance (P) for Parallelism

Model NH	P			unit = μm
Model No.	Clearance T0	Clearance T1	Normal Clearance	
15	—	18	25	
20	18	20	25	
25	20	22	30	
30	27	30	40	
35	30	35	50	
45	35	40	60	
55	45	50	70	
65	55	60	80	

Error Allowance Between Two Rails

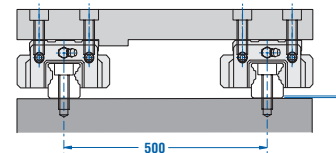

Permissible Tolerance (S) for Two Level

TWO LEVEL OFFSET: The values in the figures show the permissible tolerances for the rail-to-rail distance of 500 mm. The permissible values are proportional to the rail-to-rail distances.

Model NH	S			unit = μm
Model No.	Clearance T0	Clearance T1	Normal Clearance	
15	—	85	130	
20	50	85	130	
25	70	85	130	
30	90	110	170	
35	120	150	210	
45	140	170	250	
55	170	210	300	
65	200	250	350	

NH-EB • NH-LEB series
heavy load • flange-mount
four through holes

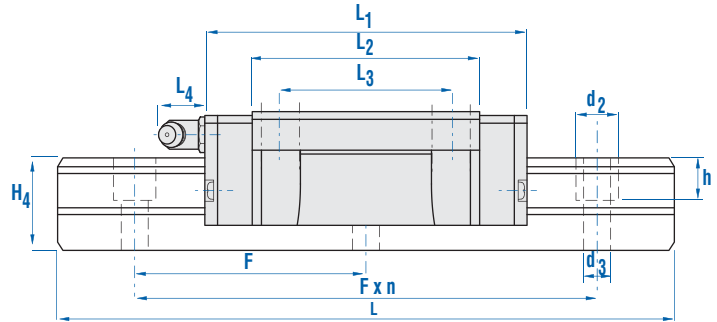

NOOK Precision Profile Rail Systems provide stable and efficient linear motion guidance under variable speeds and high load conditions.

- Interchangeable with other manufacturers
- NH-EB provides Heavy Load with Flange
- NH-LEB provides Heavy Load with Long Slide Unit
- Precision Class: C0001 - C7
- Preload: T - T3
- Maximum Rail Length:
 15, 20, 45, 55, 65 - 3000mm
 25, 30, 35 - 4000mm

Model	assembly dimensions			runner block dimensions								grease fitting
	height H	width W ₁	length L ₁	W ₂	L ₃	d ₁	L ₂	H ₃	L ₄	W ₃	H ₁	
NH15EB	24	47	58.5	38	30	4.5	38.5	7	0	4.5	4.6	NAS516-1A
NH20EB	30	63	73	53	40	6	50	8	0	5	5	NAS516-1A
NH25EB	36	70	83	57	45	7	59	10	12	6.5	6.5	B-M6F
NH25LEB	36	70	107	57	45	7	83	10	12	6.5	6.5	B-M6F
NH30EB	42	90	97	72	52	9	68	13	12	9	7	B-M6F
NH30LEB	42	90	123	72	52	9	94	13	12	9	7	B-M6F
NH35EB	48	100	112	82	62	9	80	13	12	9	8	B-M6F
NH35LEB	48	100	141	82	62	9	109	13	12	9	8	B-M6F
NH45EB	60	120	139	100	80	11	102	15	14	10	11	B-PT 1/8
NH45LEB	60	120	167	100	80	11	130	15	14	10	11	B-PT 1/8
NH55EB	70	140	159	116	95	14	124	17	16	12	14	B-PT 1/8
NH55LEB	70	140	191	116	95	14	156	17	16	12	14	B-PT 1/8
NH65EB	85	170	188	142	110	16	148	20	16	14	14	B-PT 1/8
NH65LEB	85	170	247	142	110	16	207	20	16	14	14	B-PT 1/8

See unit conversion on page 48

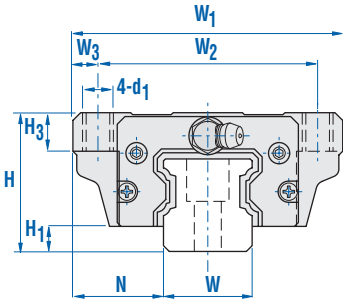

rail dimensions					load ratings										weights	
height H ₄	width W	N	pitch F	d ₃ x d ₂ x h	basic load ratings				static moment ratings						block	rail
					C		C ₀		M _A		M _B		M _C		kg	kg/m
					kN	lbf	kN	lbf	kN-m	lb-in	kN-m	lb-in	kN-m	lb-in		
17	15	16	60	4.5 x 7.5 x 7	8.43	1,895	13.53	3,041	0.07	608	0.07	608	0.13	1,128	0.19	1.7
21	20	21.5	60	6 x 9.5 x 11	13.92	3,130	23.83	5,157	0.16	1,389	0.16	1,389	0.26	2,344	0.4	2.8
24	23	23.5	60	7 x 11 x 11	20.00	4,496	34.42	7,736	0.27	2,430	0.27	2,430	0.44	3,906	0.69	3.7
24	23	23.5	60	7 x 11 x 11	27.36	6,149	45.89	10,314	0.47	4,166	0.47	4,166	0.64	5,642	0.97	3.7
28	28	31	80	9 x 14 x 14	28.24	6,347	46.87	10,535	0.43	3,819	0.43	3,819	0.72	6,336	1.8	5.3
28	28	31	80	9 x 14 x 14	37.55	8,441	62.56	14,061	0.73	6,423	0.73	6,423	0.98	8,680	1.8	5.3
32	34	33	80	9 x 14 x 15	37.55	8,441	62.56	14,061	0.64	5,642	0.64	5,642	1.13	9,982	1.8	7.5
32	34	33	80	9 x 14 x 15	50.30	11,306	81.59	18,337	1.13	9,982	1.13	9,982	1.64	14,496	2.5	7.5
42	45	37.5	105	14 x 20 x 21	60.21	13,532	95.71	21,510	1.30	11,544	1.30	11,544	2.30	20,398	3.1	12.9
42	45	37.5	105	14 x 20 x 21	80.61	18,116	127.48	28,651	2.11	18,662	2.11	18,662	3.13	27,689	4.0	12.9
48	53	43.5	120	16 x 23 x 24	90.02	20,232	137.09	30,811	2.22	19,617	2.22	19,617	4.16	37,671	5.1	17.3
48	53	43.5	120	16 x 23 x 24	119.05	26,756	183.09	41,147	3.71	32,810	3.71	32,810	5.31	47,046	6.5	17.3
58	63	53.5	150	18 x 26 x 25	141.11	31,714	215.15	48,354	4.21	37,237	4.21	37,237	7.38	65,360	9.1	24.9
58	63	53.5	150	18 x 26 x 25	192.11	43,175	286.15	64,310	7.21	63,798	7.21	63,798	10.75	95,133	13.1	24.9

The specifications and data in this publication are believed to be accurate and reliable. However, it is the responsibility of the product user to determine the suitability of Nook Industries products for a specific application. While defective products will be replaced without charge if promptly returned, no liability is assumed beyond such replacement.