



NOOK INDUSTRIES PRECISION LOCKNUTS



NOOK
INDUSTRIES
...THE LINEAR MOTION PEOPLE



NOOK Precision Locknuts

Nook precision locknuts are designed to provide adjustment, preload and secure bearings or machine components to shafts and other rotating machine elements. These locknuts allow accurate setting of preload on bearings and are capable of supporting axial loads with very high rigidity without loosening. They also provide very high load carrying capacities by continuous contact of the thread flanks around the circumference.

All Nook locknuts provide locking and loosening prevention within the part itself without the need of additional components, keys or extra machining. The prevention against loosening is accomplished in several ways, depending on the locknut series.

For series MF, MR, TMF and SFZ, locking is accomplished by using brass radial inserts, loaded and secured by setscrews. Series MF, MR and TMF have ground threads and very low axial run-out of 0.002 mm (.00008"). Series SFZ have machined threads with axial run-out contained within 0.005 mm (.0002").

For series MKR, locking is accomplished by axially shifting a portion of the threads. The design provides increased loosening prevention due to its large contact area. Series MKR have machined threads with axial run-out contained within 0.005 mm (.0002").

Every Nook locknut is manufactured with very low axial run-out. This enables accurate assembly and uniform loading of bearings and other components. The quality of the threaded contacts provide consistent loading even in repetitive assembly (tightening) and disassembly (loosening).

In order to maximize the load-ability of the locknuts the mating thread must be of suitable quality and strength. The dimension tables show static load ratings (C_A) and loosening torque based upon thread quality class ISO 6g or better (4h for high precision applications, such as spindles should be used) and material strength of 690 N/mm² (100,000 PSI). The geometrical tolerances should also be verified. The surface finish of the components (i.e. thread flanks) should not exceed 0.8 μm Ra (32 μinch).

APPLICATIONS

As shown below, Nook locknuts can be used to assemble springs, adjust the axial play on thrust washers, adjust the preload and locate axially thrust bearings in spindle arrangements and ball screw supports.

Ball Screw Application

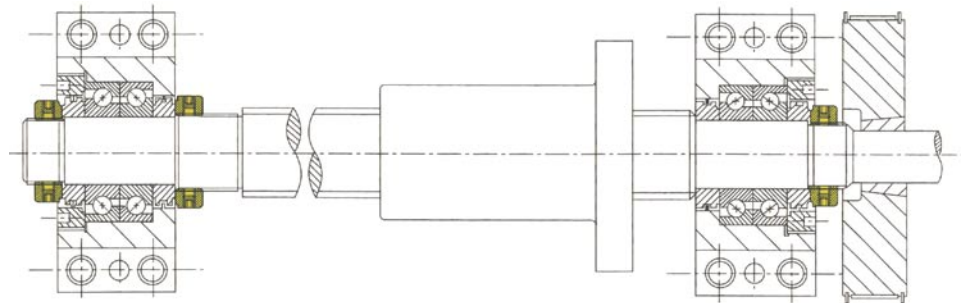

Spindle Application

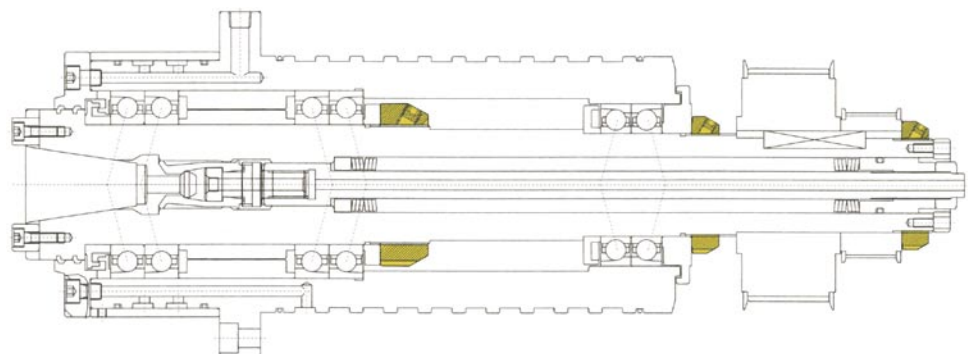

LOCKNUT DESIGNS

Nook precision locknuts are produced from high strength steel, heat-treated to a hardness of 28 to 32 HRC. The heat treat process produces additional strength and high resilience to shock loads. The locknuts have either ground threads or machined threads with a tolerance class of ISO 4H.

SERIES MF

The series MF locknut is designed with three locking inserts (pegs) that intersect the bore with an angle of 30°. This series is produced with tolerance class ISO 4H ground threads and is available in sizes 12 to 200 mm bore.



SERIES MR

The series MR locknut is designed with three locking inserts (pegs) that intersect the bore with an angle of 90°. This design offers reduced axial space requirements, which limits its use to applications where the locking pegs are accessible. The reduced axial length also reduces the axial loading capacity. This series is produced with tolerance class ISO 4H ground threads and is available in sizes 6 to 200 mm bore.



SERIES MKR

The series MKR locknut design utilizes two radial grooves machined to provide an accordion-like cross section. The internal radial groove divides the thread of the locknut into two sections: locking section and clamping section. Depending on the locknut size, three to eight socket head screws are used to clamp the two sections together. By tightening the socket head screws, the thread clearance is eliminated providing a continuous contact along the entire thread length. This continuous contact provides high load carrying capacity, high shock resistance and high loosening torque.



The two sections are designed so the deformation induced by the socket head screws is occurring only in the locking portion of the locknut without affecting the accuracy of the clamping portion. This series is produced with tolerance class ISO 4H machined threads and is available in sizes 10 to 200 mm bore.

SERIES TMF

The series TMF locknut is designed with three locking inserts (pegs) that intersect the bore with an angle of 30°. This series is produced with tolerance class ISO 4H ground threads and is available in sizes 25 to 200 mm bore.



SERIES SFZ

The series SFZ locknut is designed with three locking inserts (pegs) that intersect the bore with an angle of 30°. This series is produced with tolerance class ISO 4H machined threads and is available in sizes 10 to 200 mm bore.





LOAD RATINGS

The load ratings published in the dimension tables are for axial loads of constant magnitude under static conditions and have been calculated with a safety factor of 2 or greater to the material yield strength. Dynamic loads will stress the parts in fatigue and therefore should be verified for each application. As a guideline, the dynamic load should never exceed 75% of the published values.

CALCULATION OF TIGHTENING TORQUE

The axial load of a threaded connection is critical to the proper function of the equipment, thus the setting of the preload must be performed with great accuracy. Direct measurement of this variable is not easily accomplished and most production facilities lack proper means to do so. To prevent this problem, a calculation must be performed to correlate the locknut tightening torque to the required clamping load.

$$M = F_a \times (f \times D_M/2 + f_1 \times D_T/2) \times 10^{-3} \text{ [N}\cdot\text{m]}$$

Where:

F_a = axial clamping load required [N]

f = coefficient of friction between locknut face and clamping surface [-]

D_M = mean diameter of locknut contacting face [mm]

f_1 = coefficient of friction of thread flanks [-]

D_T = thread diameter from dimension tables [mm]

The calculation of D_M is shown in the pictures below. The mean value of the coefficient of friction f is 0.14.

MR

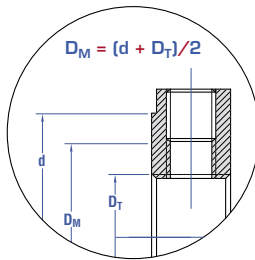

MF

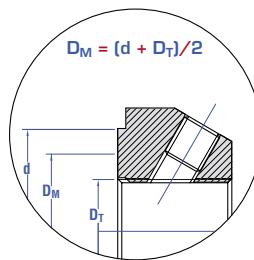

TMF & SFZ

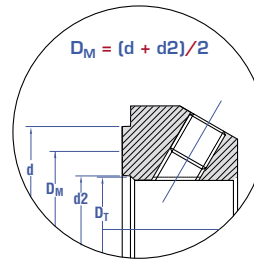

MKR

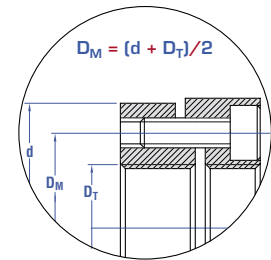

The coefficient of friction f_1 is calculated as follows:

$$f_1 = \tan(\alpha + \beta)$$

Where:

α = friction angle (mean value 9.2°)

β = thread lead angle

$$\beta = \tan^{-1} \left(\frac{\text{Lead}}{D_T \times \pi} \right)$$

Where:

Lead (pitch) and D_T – thread diameter from dimensions table.

This tightening torque value can be easily verified and reproduced by using a simple torque wrench.

Note:

The loosening torque should be verified in applications where angular acceleration/deceleration are very high. In applications where the mass of the locknut (and its inertia) could impart a large torque to the unit, and analytical verification should be made. Nook engineers are available to assist you with the proper locknut selection.

INSTALLATION/MOUNTING

Series MF, MR, MKR, TMF, SFZ

The design of the mounting elements is the responsibility of the user.

Tools

Appropriate tools for tightening and locating the locknuts include:

- Spanner wrenches (i.e. DIN 1810 A _)
- Universal socket wrench with square socket.

If locknuts and locking screws are fitted using tool combinations adapted in-house, it is absolutely essential that the installation guidelines given for the fitting and the specified tightening torques be strictly adhered to.

Preloading of bearings and axial clamping

The tightening torque M (calculated as shown) can be applied by means of:

- The lead screw drive—In this case, the locknut must be prevented from rotating.
- The locknut—In this case, the screw/shaft must be prevented from rotating.
- Lightly oil the thread on the screw/shaft.
- Screw the locknut onto the thread, tighten to twice the tightening torque value M and loosen again. This will prevent any settling effects.
- Tighten the locknut firmly to the tightening torque M.

Locating the precision locknut

- Tighten the setscrews (or the cap screws for the MKR product), evenly and in a crosswise sequence in two steps to the specified tightening torque (T) indicated in the dimension tables.
- First step, tighten to half the value of T.
- Second step, tighten to the fully recommended value of T.

Removing the precision locknut

If handled correctly, the locknuts can be reused several times. In order to remove the locknut:

- Loosen the setscrews (or cap screws for the MKR product).
- Loosen the locking pegs by light blows with a rubber/plastic mallet on the outer cylindrical surface in the vicinity of the threaded setscrew holes. This will prevent damage to the thread when unscrewing the nut (this step is not required with the MKR product).
- Loosen the locknut using the pertinent wrench and unscrew by hand.
- Please make sure to prevent the screw/shaft from rotating while loosening the locknut.

HOW TO ORDER

To generate a part number for ordering a precision locknut, specify the correct designations from the chart, see examples below. For further assistance contact our engineering department.

Examples:

MR 20x1.5

MR Series Radial Locking right hand Locknut
20 nominal thread diameter with 1.5 lead

MKR 10x0.75L

MKR Series Axial Locking left hand Locknut
10 nominal thread diameter with 0.75 lead

MF 25x1L*



* not stocked items



MF Series—30° Locking

- Material—AISI 4140
- Hardness—HRC 28-32
- Precision—ISO 4H

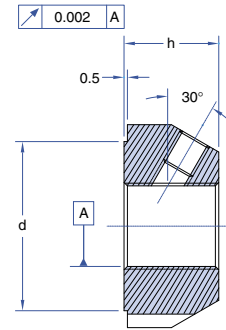
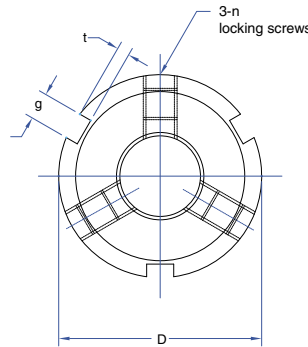

Part Number	Dimensions in mm					Locking Screws				
	D _T P	D	h	g	t	d	DIN	Max Tightening Torque (T) N•m	Allowable Axial Load (C _a) kN	Loosening Torque (T) N•m
MF 12x1		30	14	4	2	25	M5	4.7	40	20
MF 15x1		34	16	4	2	26	M6	8	60	25
MF 17x1		36	16	5	2	28	M6	8	70	30
MF 20x1		38	18	5	2	32	M6	8	90	40
MF 20x1.5		38	18	5	2	32	M6	8	90	40
MF 25x1.5		42	18	5	2	36	M6	8	120	80
MF 30x1.5		48	18	5	2	43	M6	8	145	140
MF 35x1.5		53	18	5	2	48	M8	18.6	170	180
MF 40x1.5		58	20	6	2.5	52	M8	18.6	190	220
MF 45x1.5		65	20	6	2.5	59	M8	18.6	220	250
MF 50x1.5		70	20	6	2.5	64	M8	18.6	250	270
MF 55x2		75	22	7	3	68	M8	18.6	310	290
MF 60x2		80	22	7	3	73	M8	18.6	350	310
MF 65x2		85	22	7	3	78	M8	18.6	400	320
MF 70x2		92	24	8	3.5	84	M8	18.6	450	340
MF 75x2		98	24	8	3.5	90	M8	18.6	480	360
MF 80x2		105	24	8	3.5	96	M8	18.6	580	380
MF 85x2		112	24	8	3.5	104	M8	18.6	620	400
MF 90x2		118	26	10	4	108	M8	18.6	680	450
MF 100x2		128	26	10	4	118	M8	18.6	740	500
MF 110x2		145	30	12	5	132	M8	18.6	800	550
MF 120x2		155	30	12	5	142	M8	18.6	860	600
MF 130x2		165	30	12	5	152	M8	18.6	920	650
MF 140x2		180	32	12	5	165	M10	35	980	700
MF 150x2		195	32	12	5	180	M10	35	1050	750
MF 160x3		210	34	12	5	190	M10	35	1200	800
MF 170x3		220	34	12	5	200	M10	35	1260	850
MF 180x3		230	36	12	5	205	M10	35	1370	900
MF 190x3		240	36	12	5	220	M10	35	1430	950
MF 200x3		250	36	12	5	230	M10	35	1500	990

When ordering the above products, please refer to the HOW TO ORDER section on page 5.

The specifications and data in this publication are believed to be accurate and reliable. However, it is the responsibility of the product user to determine the suitability of Nook Industries products for a specific application. While defective products will be replaced without charge if promptly returned, no liability is assumed beyond such replacement.

MR Series—Radial Locking



- Material—AISI 4140
- Hardness—HRC 28-32
- Precision—ISO 4H

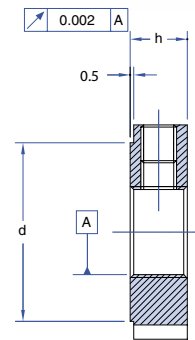
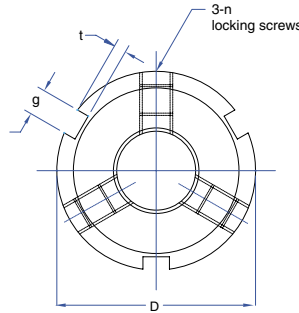

Part Number	Dimensions in mm					Locking Screws				
	D _T P	D	h	g	t	d	DIN	Max Tightening Torque (T) N•m	Allowable Axial Load (C _a) kN	Loosening Torque (T) N•m
MR 6x0.5		16	8	3	2	11	M4	2	7.8	11
MR 8x0.75		16	8	3	2	11	M4	2	10.2	15
MR 10x0.75		18	8	3	2	13	M4	2	11	18
MR 12x1		24	8	3	2	19	M4	2	20	19
MR 15x1		28	8	3	2	23	M4	2	30	22
MR 17x1		32	10	4	2	27	M5	4.7	40	28
MR 20x1		35	10	4	2	30	M5	4.7	50	30
MR 20x1.5		35	10	4	2	30	M5	4.7	50	30
MR 25x1.5		42	12	5	2	36	M6	8	75	55
MR 30x1.5		48	12	5	2	43	M6	8	90	75
MR 35x1.5		53	12	5	2	48	M6	8	110	90
MR 40x1.5		58	14	6	2.5	52	M6	8	130	120
MR 45x1.5		65	14	6	2.5	59	M6	8	150	130
MR 50x1.5		70	14	6	2.5	64	M6	8	175	150
MR 55x2		75	16	7	3	68	M8	18.6	225	170
MR 60x2		80	16	7	3	73	M8	18.6	250	200
MR 65x2		85	16	7	3	78	M8	18.6	290	220
MR 70x2		92	18	8	3.5	84	M8	18.6	340	240
MR 75x2		98	18	8	3.5	90	M8	18.6	360	260
MR 80x2		105	18	8	3.5	96	M8	18.6	430	280
MR 85x2		112	18	8	3.5	104	M8	18.6	460	300
MR 90x2		118	20	10	4	108	M8	18.6	520	320
MR 100x2		128	20	10	4	118	M8	18.6	570	360
MR 110x2		145	24	12	5	132	M8	18.6	640	400
MR 120x2		155	24	12	5	142	M8	18.6	680	450
MR 130x2		165	24	12	5	152	M8	18.6	730	500
MR 140x2		180	26	12	5	165	M10	35	800	550
MR 150x2		195	26	12	5	180	M10	35	850	600
MR 160x2		210	28	12	5	190	M10	35	980	650
MR 170x2		220	28	12	5	200	M10	35	1030	700
MR 180x3		230	30	12	5	210	M10	35	1140	750
MR 190x3		240	30	12	5	220	M10	35	1200	800
MR 200x3		250	30	12	5	230	M10	35	1250	850

When ordering the above products, please refer to the HOW TO ORDER section on page 5.





MKR Series—Axial Locking

- Material—AISI 4140
- Hardness—HRC 28-32
- Precision—ISO 4H

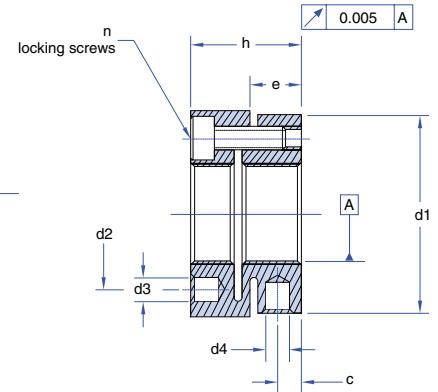
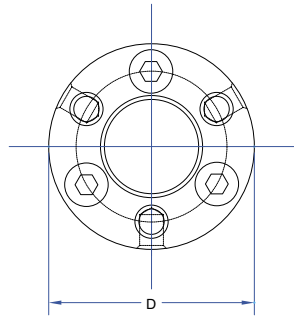

Part Number	Dimensions in mm									Locking Screws				
	D _T	P	D	h	e	d1	d2	d3	d4	c	DIN	n	Max Tightening Torque (T) N•m	Allowable Axial Load (C _a) kN
MKR 10x0.75			24	14	6.5	22	17	3.2	2.5	3	M3x10	3	2	12
MKR 10x1			24	15	6.5	22	17	3.2	2.5	3	M3x10	3	2	12
MKR 12x1			26	14	6.5	25	19	3.2	3	3	M3x10	3	2	14
MKR 12x1.5			26	15	6.5	25	19	3.2	3	3	M3x10	3	2	13
MKR 14x1.5			32	16	7	30	22.5	4.3	4	3	M4x10	3	2.9	17
MKR 15x1			33	16	7	31	23.5	4.3	4	3	M4x10	3	2.9	19
MKR 16x1.5			34	18	—	—	24.5	4.3	4	5	M4x12	4	2.9	17
MKR 17x1			35	18	—	—	25.5	4.3	4	5	M4x12	4	2.9	19
MKR 18x1.5			36	18	—	—	26.5	4.3	4	5	M4x12	4	2.9	19
MKR 20x1			40	18	—	—	30.5	4.3	4	5	M4x12	4	2.9	22
MKR 20x1.5			40	18	—	—	30.5	4.3	4	5	M4x12	4	2.9	18
MKR 22x1.5			40	18	—	—	30.5	4.3	4	5	M4x12	4	2.9	23
MKR 24x1.5			42	18	—	—	32.5	4.3	4	5	M4x12	4	2.9	25
MKR 25x1.5			45	20	—	—	36.5	4.3	5	6.5	M4x12	4	2.9	33
MKR 26x1.5			45	20	—	—	36.5	4.3	5	6.5	M4x12	4	2.9	34
MKR 28x1.5			46	20	—	—	38.5	4.3	5	6.5	M4x12	4	2.9	36
MKR 30x1.5			48	20	—	—	40.5	4.3	5	6.5	M4x12	4	2.9	38
MKR 32x1.5			50	22	—	—	42.5	4.3	5	7	M4x16	4	2.9	44
MKR 35x1.5			53	22	—	—	45.5	4.3	5	7	M4x16	4	2.9	47
MKR 38x1.5			58	22	—	—	48.5	4.3	5	7	M4x16	4	2.9	50
MKR 40x1.5			58	22	—	—	50.5	4.3	5	7	M4x16	4	2.9	49
MKR 42x1.5			60	22	—	—	52.5	4.3	5	7	M4x16	4	2.9	49
MKR 45x1.5			68	22	—	—	58	4.3	6	6.5	M4x16	6	2.9	53
MKR 48x1.5			68	25	—	—	59.5	4.3	6	9	M4x16	6	2.9	70
MKR 50x1.5			70	25	—	—	61.5	4.3	6	9	M4x16	6	2.9	71
MKR 52x1.5			72	25	—	—	63.5	4.3	6	9	M4x16	6	2.9	72
MKR 55x1.5			75	25	—	—	66.5	4.3	6	9	M4x16	6	2.9	72
MKR 55x2			75	25	—	—	66.5	4.3	6	9	M4x16	6	2.9	72
MKR 58x1.5			82	26	—	—	72.5	5.3	6	9	M5x16	6	6	122

When ordering the above products, please refer to the HOW TO ORDER section on page 5.

The specifications and data in this publication are believed to be accurate and reliable. However, it is the responsibility of the product user to determine the suitability of Nook Industries products for a specific application. While defective products will be replaced without charge if promptly returned, no liability is assumed beyond such replacement.

MKR Series—Axial Locking



- Material—AISI 4140
- Hardness—HRC 28-32
- Precision—ISO 4H

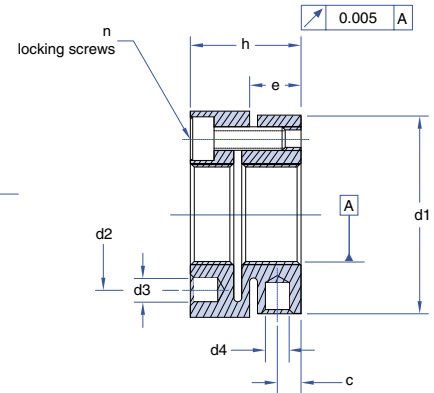
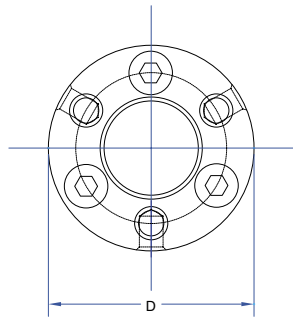

Part Number	Dimensions in mm									Locking Screws				
	D _T	P	D	h	e	d1	d2	d3	d4	c	DIN	n	Max Tightening Torque (T) N•m	Allowable Axial Load (C _a) kN
MKR 60x1.5			84	26	—	—	74.5	5.3	6	9	M5x16	6	6	123
MKR 60x2			84	26	—	—	74.5	5.3	6	9	M5x16	6	6	123
MKR 62x1.5			86	28	—	—	76.5	5.3	6	10.5	M5x20	6	6	141
MKR 65x1.5			88	28	—	—	78.5	5.3	6	10.5	M5x20	6	6	134
MKR 65x2			88	28	—	—	78.5	5.3	6	10.5	M5x20	6	6	134
MKR 68x1.5			95	28	—	—	83	5.3	8	9.5	M5x20	6	6	168
MKR 70x1.5			95	28	—	—	85	5.3	8	9.5	M5x20	6	6	153
MKR 70x2			95	28	—	—	85	5.3	8	9.5	M5x20	6	6	153
MKR 72x1.5			98	28	—	—	86	6.4	8	8.5	M6x20	6	10	128
MKR 75x1.5			100	28	—	—	88	6.4	8	8.5	M6x20	6	10	121
MKR 75x2			100	28	—	—	88	6.4	8	8.5	M6x20	6	10	121
MKR 80x2			110	32	—	—	95	6.4	8	11	M6x20	6	10	194
MKR 85x2			115	32	—	—	100	6.4	8	11	M6x20	6	10	198
MKR 90x2			120	32	—	—	108	6.4	8	11	M6x20	6	10	200
MKR 95x2			125	32	—	—	113	6.4	8	11	M6x20	6	10	203
MKR 100x2			130	32	—	—	118	6.4	8	11	M6x20	6	10	205
MKR 105x2			135	32	—	—	123	6.4	8	11	M6x20	6	10	207
MKR 110x2			140	32	—	—	128	6.4	8	11	M6x20	6	10	212
MKR 115x2			145	36	—	—	133	6.4	8	13	M6x25	6	10	248
MKR 120x2			155	36	—	—	140	6.4	8	13	M6x25	6	10	308
MKR 125x2			160	36	—	—	148	6.4	8	13	M6x25	6	10	311
MKR 130x3			165	36	—	—	153	6.4	8	13	M6x25	6	10	306
MKR 140x3			180	36	—	—	165	6.4	10	12	M6x25	8	10	359
MKR 150x3			190	36	—	—	175	6.4	10	12	M6x25	8	10	369
MKR 160x3			205	40	—	—	185	8.4	10	14	M8x30	8	25	417
MKR 170x3			215	40	—	—	195	8.4	10	14	M8x30	8	25	423
MKR 180x3			230	40	—	—	210	8.4	10	14	M8x30	8	25	489
MKR 190x3			240	40	—	—	224	8.4	10	14	M8x30	8	25	495
MKR 200x3			245	40	—	—	229	8.4	10	14	M8x30	8	25	436

When ordering the above products, please refer to the HOW TO ORDER section on page 5.

The specifications and data in this publication are believed to be accurate and reliable. However, it is the responsibility of the product user to determine the suitability of Nook Industries products for a specific application. While defective products will be replaced without charge if promptly returned, no liability is assumed beyond such replacement.



TMF Series—30° Locking

- Material—AISI 4140
- Hardness—HRC 28-32
- Precision—ISO 4H

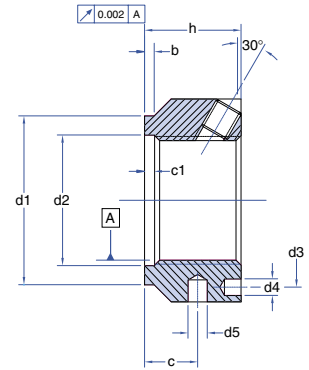
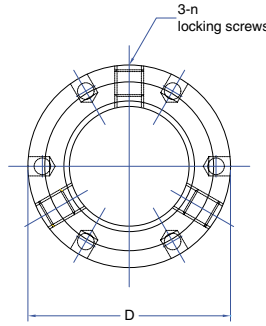

Part Number	Dimensions in mm										Locking Screws					
	D _T	P	D	h	d1	d2	d3	d4	d5	b	c	c1	DIN	Max Tightening Torque (T) N•m	Allowable Axial Load (C _a) kN	Loosening Torque (T) N•m
TMF 25x1.5			42	20	35	26	32.5	4.3	4	2	11	2	M6	8	130	45
TMF 30x1.5			48	20	40	32	40.5	4.3	5	2	11	2	M6	8	160	55
TMF 35x1.5			53	20	47	38	45.5	4.3	5	2	11	2	M6	8	190	65
TMF 40x1.5			58	22	52	42	50.5	4.3	5	2	12	2	M6	8	210	80
TMF 45x1.5			68	22	58	48	58	4.3	6	2	12	2	M6	8	240	95
TMF 50x1.5			70	24	63	52	61.5	4.3	6	2	13	2	M6	8	300	115
TMF 55x1.5			75	24	70	58	66.5	4.3	6	3	13	3	M6	8	340	135
TMF 60x1.5			84	24	75	62	74.5	5.3	6	3	13	3	M6	8	380	150
TMF 65x1.5			88	25	80	68	78.5	5.3	6	3	13	3	M6	8	460	170
TMF 70x1.5			95	26	86	72	85	5.3	8	3	14	3	M8	18.6	490	285
TMF 75x1.5			100	26	91	77	88	6.4	8	3	15	3	M8	18.6	520	305
TMF 80x2			110	30	97	83	95	6.4	8	3	16	3	M8	18.6	620	325
TMF 85x2			115	32	102	88	100	6.4	8	3	17	3	M10	35	650	660
TMF 90x2			120	32	110	93	108	6.4	8	3	17	3	M10	35	680	720
TMF 95x2			125	32	114	98	113	6.4	8	3	17	3	M10	35	710	780
TMF 100x2			130	32	120	103	118	6.4	8	3	17	3	M10	35	740	840
TMF 110x2			140	32	132	112	128	6.4	8	3	17	3	M10	35	800	960
TMF 120x2			155	32	142	122	140	6.4	8	3	17	3	M10	35	860	1080
TMF 130x2			165	32	156	132	153	6.4	8	3	17	3	M10	35	920	1200
TMF 140x3			180	32	166	142	165	6.4	10	3	17	3	M10	35	980	1320
TMF 150x3			190	32	180	152	175	6.4	10	5	17	5	M10	35	1040	1440
TMF 160x3			205	32	190	162	185	8.4	10	5	17	5	M10	35	1100	1600
TMF 170x3			215	32	205	172	195	8.4	10	5	17	5	M10	35	1160	1750
TMF 180x3			230	32	215	182	210	8.4	10	5	17	5	M10	35	1220	1900
TMF 190x3			240	32	225	192	224	8.4	10	5	17	5	M10	35	1280	2050
TMF 200x3			245	32	237	202	229	8.4	10	5	17	5	M10	35	1340	2200

When ordering the above products, please refer to the HOW TO ORDER section on page 5.

The specifications and data in this publication are believed to be accurate and reliable. However, it is the responsibility of the product user to determine the suitability of Nook Industries products for a specific application. While defective products will be replaced without charge if promptly returned, no liability is assumed beyond such replacement.

SFZ Series—30° Locking



- Material—AISI 4140
- Hardness—HRC 28-32
- Precision—ISO 4H

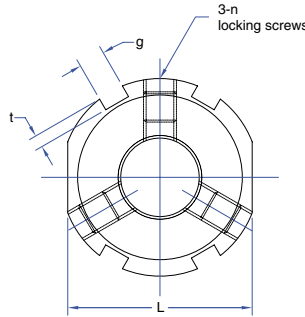

SFZ10 - SFZ75

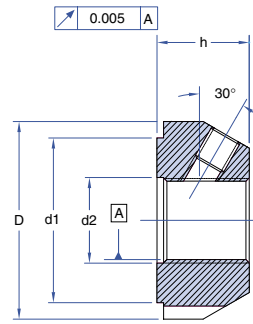

SFZ80 - SFZ110

Part Number D _r P	Dimensions in mm							Locking Screws			
	D	h	g	t	d1	d2	L	DIN	Max Tightening Torque (T) N•m	Allowable Axial Load (C _a) kN	Loosening Torque (T) N•m
SFZ 10x0.75	28	14	4	2	23	11	24	M5	4.7	35	15
SFZ 12x1	30	14	4	2	25	13	27	M5	4.7	40	18
SFZ 15x1	33	16	4	2	28	16	30	M5	4.7	60	20
SFZ 17x1	37	18	5	2	33	18	34	M6	8	80	25
SFZ 20x1	40	18	5	2	35	21	36	M6	8	90	35
SFZ 25x1.5	44	20	5	2	39	26	41	M6	8	130	45
SFZ 30x1.5	49	20	5	2	44	32	46	M6	8	160	55
SFZ 35x1.5	54	22	5	2	49	38	50	M6	8	190	65
SFZ 40x1.5	65	22	6	2.5	59	42	60	M8	18.6	210	80
SFZ 45x1.5	70	22	6	2.5	64	48	65	M8	18.6	240	95
SFZ 50x1.5	75	25	7	3	68	52	70	M8	18.6	300	115
SFZ 55x2	85	25	7	3	78	58	80	M8	18.6	340	225
SFZ 60x2	90	26	8	3.5	82	62	85	M8	18.6	380	245
SFZ 65x2	95	28	8	3.5	87	68	90	M8	18.6	460	265
SFZ 70x2	100	28	8	3.5	92	72	95	M8	18.6	490	285
SFZ 75x2	105	28	8	3.5	97	77	100	M8	18.6	520	305
SFZ 80x2	110	32	8	3.5	100	83	—	M8	18.6	620	325
SFZ 85x2	120	32	10	4	110	88	—	M10	35	650	660
SFZ 90x2	125	32	10	4	115	93	—	M10	35	680	720
SFZ 95x2	130	32	10	4	120	98	—	M10	35	710	780
SFZ 100x2	135	32	10	4	125	103	—	M10	35	740	840
SFZ 110x2	145	32	10	4	134	112	—	M10	35	800	960

When ordering the above products, please refer to the HOW TO ORDER section on page 5.

The specifications and data in this publication are believed to be accurate and reliable. However, it is the responsibility of the product user to determine the suitability of Nook Industries products for a specific application. While defective products will be replaced without charge if promptly returned, no liability is assumed beyond such replacement.



NOOK INDUSTRIES PRECISION LOCKNUTS



For more information visit:

www.nookindustries.com

The specifications and data in this publication are believed to be accurate and reliable. However, it is the responsibility of the product user to determine the suitability of Nook Industries products for a specific application. While defective products will be replaced without charge if promptly returned, no liability is assumed beyond such replacement.



NOOK
INDUSTRIES
...THE LINEAR MOTION PEOPLE

4950 East 49th Street,
Cleveland, OH 44125-1018 USA

216/271-7900
Toll Free: 800/321-7800
Fax: 216/271-7020
email: nook@nookind.com