

Modular Linear Actuator ELZT 40, 60, 80, 80S, 100

Telescopic Belt Drive

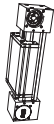

3

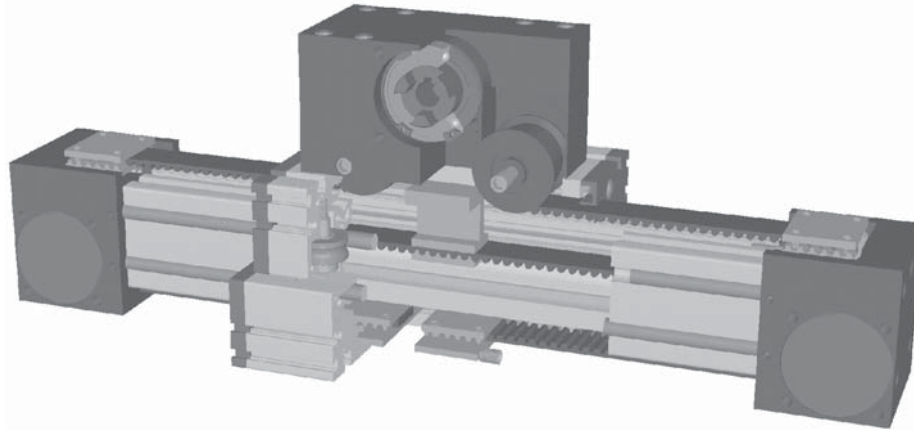

Function:

This unit consists of an aluminium extrusion body with integrated, hardened steel guide rods. Two carriages, which have internal linear ball bearings that can be adjusted free of play, are driven along the guide rods in opposite directions by two belts. The pulleys include maintenance-free ball bearings. One belt is tensioned by a tensioning device within the carriage. The other timing belt is tensioned by a tensioning device within the bearing block. The carriage with the drive block (with motor) is screwed to the crosshead. A T-slot profile is screwed to the carriage as an extension arm which can be adjusted to any length (see functional diagram on page 42).

Fitting length:

As required. Max. length 3,000 mm single/extrusion.

Unit mounting:

T-slots or tapped holes in the bearing block, mounting sets.

Belt type:

HTD with steel reinforcement minimizes backlash on reversal, no backlash when changing direction, repeatability: $\pm 0,1$ mm.

Forces and torques	Size	ELZT 40		ELZT 60		ELZT 80		ELZT 80 S		ELZT 100	
	Forces/torques	static	dynamic	static	dynamic	static	dynamic	static	dynamic	static	dynamic
F_x (N)		360	300	580	470	825	660	825	660	4000	3500
F_y (N)		1200	700	3000	2000	3000	2000	4600	3600	8000	6500
F_z (N)		900	650	1700	1100	1700	1100	3000	1800	3600	2200
M_x (Nm)		25	20	67	43	90	55	170	140	300	230
M_y (Nm)		32	18	90	70	110	80	270	230	400	270
M_z (Nm)		35	25	120	100	150	120	300	220	750	500
No-load torque											
Nm		0,9		1,1		1,3		1,2		2,4	
Speed											
(m/sec) max		4		5		6		8		8	
Tensile force											
permanent (N)		390		900		1900		1900		4000	
0,2 sec (N)		480		1000		2090		2090		4300	
Geometrical moments of inertia of aluminium profile											
I_x mm ⁴		1,32x10 ⁵		6,79x10 ⁵		18,99x10 ⁵		18,99x10 ⁵		44,4x10 ⁵	
I_y mm ⁴		1,34x10 ⁵		6,97x10 ⁵		18,97x10 ⁵		18,97x10 ⁵		44,8x10 ⁵	
E-Modulus N/mm ²		70000		70000		70000		70000		70000	

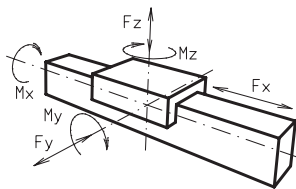

Formula: ELZT

Driving torque:

$$M_o = \frac{F \cdot P \cdot S_i}{2000 \cdot \pi} + M_{leer}$$

$$P_o = \frac{M_o \cdot n}{9550}$$

- F = force (N)
- P = pulley action perimeter (mm)
- S_i = safety factor 1,2 ... 2
- M_{leer} = No-load torque (Nm)
- n = rpm pulley (min⁻¹)
- M_o = driving torque (Nm)
- P_o = motor power (KW)

$$f = \frac{F \cdot L^3}{E \cdot I \cdot 192}$$

- f = deflection (mm)
- F = load (N)
- L = free length (mm)
- E = elastic modulus 70000 (N/mm²)
- I = second moment of area (mm⁴)

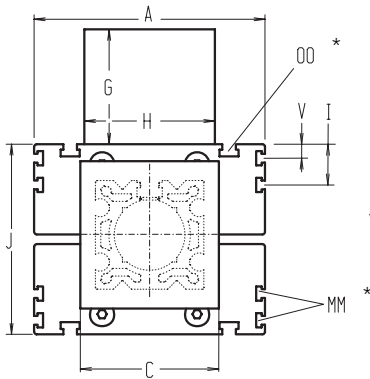

Increasing the carriage length will increase the basic length by the same amount.

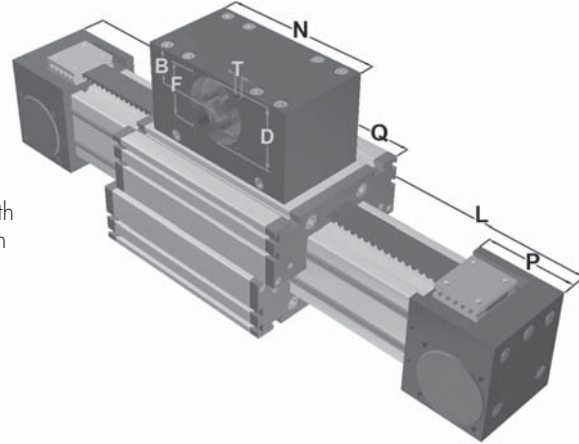

3

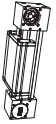

*For T-nuts refer to the accessory section

Size	Basic length L	A	B	C	D	F	G	H	I	J	MM	N	OO	P	Q	T	V	Basic weight	Additional Weight per 100 mm
ELSD 40	265	100	30	58	47	42	83	80	-	70	-	130	M6	49	162	M6	-	3,6 kg	0,31 kg
ELSD 60	345	144	39	80	68	60	105	100	-	98	-	180	M8	59	218	M8	-	9,1 kg	0,73 kg
ELSD 80	494	170	60	100	90	80	140	130	30	140	M6	270	M10	90	304	M10	10	24,0 kg	1,14 kg
ELSD 80S	494	190	60	100	90	80	140	130	30	142	M6	270	M8	90	304	M10	12,5	26,0 kg	1,14 kg
ELSD 100	530	230	62	130	110	100	143	160	30	180	M10	310	M10	110	350	M10	-	40,6 kg	1,95 kg

Choice of guide body profile:

0 (0) standard (1) stainless guide rods (2) stainless guide rods and screws (3) stainless guide rods, rollers and screws

Choice of carriages:

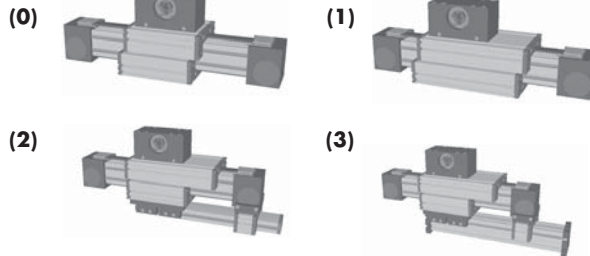

The carriages can be provided in any non-standard length upon request; the longer the carriage, the greater the load capacity. Increasing the carriage length will increase the basic length by the same amount.

Coupling - shaft mounting

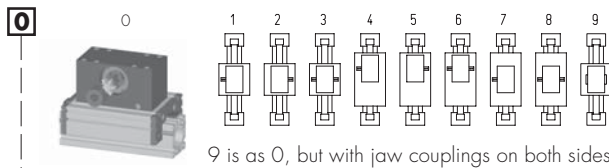

The standard version is supplied with jaw coupling. A shaft can be retrofitted by inserting in the pulley bore and securing with 2 locking rings or tension sets (size 80 +100).

Belt table

Code No.	Size	Belt	mm/rev.	Number of teeth
0 4	40	5M25	130	26
0 7	60	8M30	192	24
0 9	80 (S)	8M50	256	32
1 0	100	8M70	304	38

Shaft dimensions

Size	Shaft ø h6 x length	Key
40	14 x 35	5x5x28
60	18 x 45	6x6x40
80 (S)	22 x 45	6x6x40
100	30 x 55	8x7x40

Basic length + 1/2stroke = total length

ELZT 60 6 0 0 0 0 7 1 01500

Pos. 1 2 3 4 5 6 7

Sample ordering code:

ELZT 60 with standard body profile, standard carriage and jaw coupling on one side, 1155 mm stroke

Operating Principle and Application Example

ELZT Belt Drive Unit

3

