



APPLICATION:

The Type K Rotary Limit Switch is used in applications requiring ratios from 5:1 to 1080:1 for controlling the end and/or intermediate limits of a reciprocating or rotary motion. Two circuit and four circuit assemblies are available from stock.

The NEMA 4 & 5 enclosure provides a clean environmental condition for the industrial duty snap action switches. Where motion can be expressed in shaft rotation either through a roller chain, gear train or direct coupling, the Type K Rotary Limit Switch makes it possible to open or close up to four independent circuits at the desired angular positions.

DESCRIPTION:

Precision rugged duty snap action switches, combined with a wide selection of gear ratios provides reliable electrical signals as a function of the shaft rotation. No minimum speed is specified due to the snap action contacts of the switch. The cam settings and the switch wiring can be easily accomplished through the full size cover.

With the two circuit assembly, either a left hand or right hand shaft extension can be supplied. This provides the added versatility when packaging this assembly in hard-to-get-at locations.

Ease of Making Cam Settings

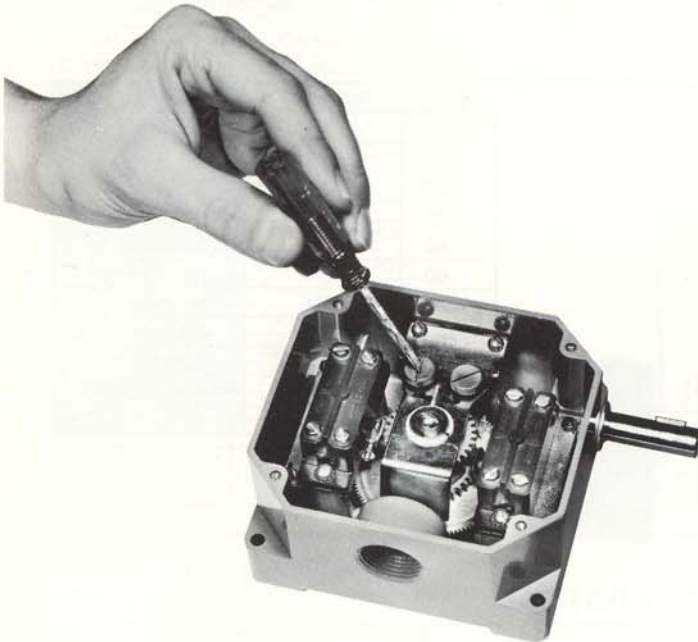

Easy to Wire Terminals

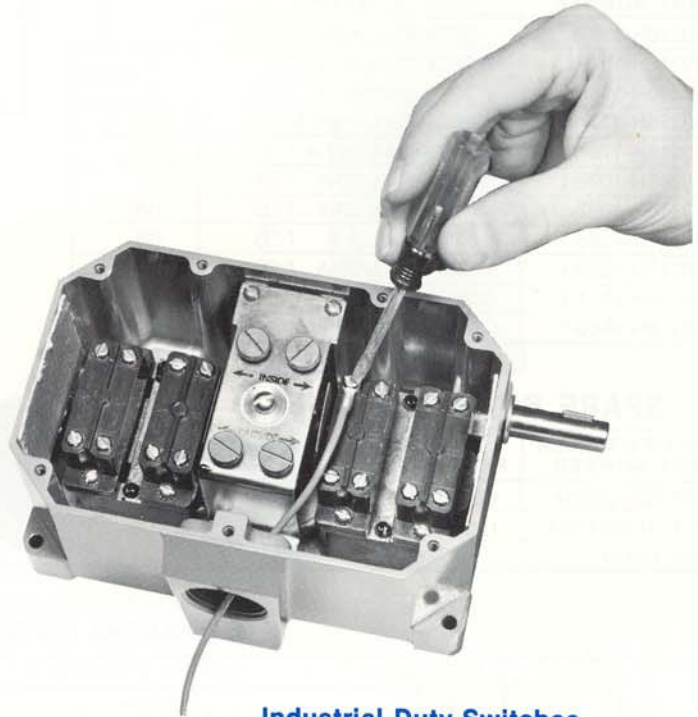

TYPICAL APPLICATIONS ARE:

- Door Operators
- Hoists
- Valves
- Elevating Jack Mechanisms
- Tapping Heads
- Packaging Machinery
- Index Tables
- Material Handling Equipment
- Reciprocating Linear Actuators
- Dampers
- End Limits on Machine Tool Lead Screws
- Shuttles
- Conveyors

Industrial Duty Switches With Isolated Contacts

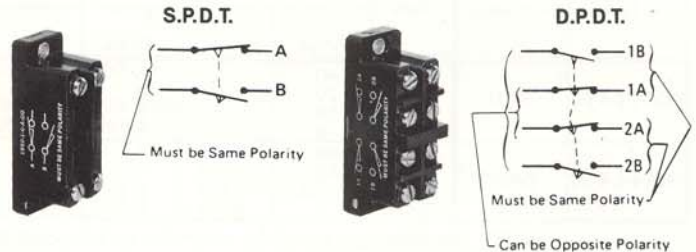



2 Circuit Type K Rotary Limit Switch

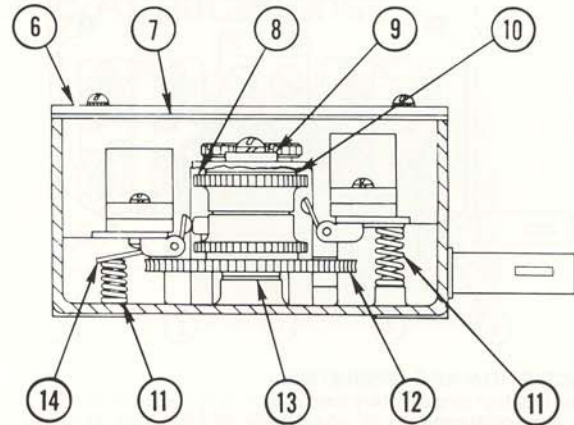
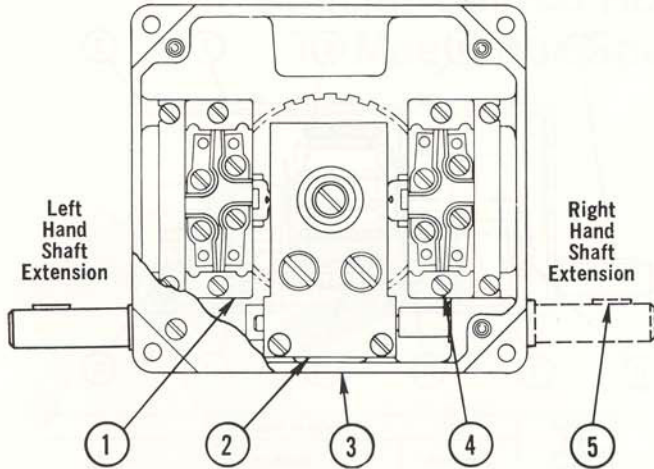

DESCRIPTION

This rotary limit switch is designed to control the limits of travel of rotating reversing equipment.

The limit switch input shaft is connected to a worm gear. Adjustable self lubricating nylon roller cams are concentrically mounted on the worm gear. These adjustable cams actuate the single pole double throw precision limit switch units.

INSTALLATION

This limit switch may be mounted in any convenient position. When installed this limit switch will provide long life with a minimum amount of service maintenance.

The following recommendations will prove helpful.

- 1—Install the limit switch so that the shaft load will not exceed five pounds.
- 2—A flexible coupling is recommended for all installations other than gear drives.
- 3—Couplings should be employed in a manner that results in a minimum of thrust loading of the shaft. If switches are mounted with the shaft up or down, some additional thrust loading resulting from the weight of the shaft plus a very light coupling is permissible.
- 4—Whenever possible, a separate support bearing for the drive sprocket should be used.
- 5—Permissible speed of the input shaft 2000 R.P.M.

ADJUSTMENT

Refer to figure 1. The electrical switch units "G" and "H" are shown with the contact positions assumed when the cams are not actuating the switch units.

When the cam rotates and actuates the switch, the "B" (closed) contact opens and the "A" (open) contacts close. Each electrical switch unit has its independent adjustable cam.

To Adjust "G" Switch

- 1—Loosen screw "E".
- 2—Turn screw "C" until cam roller trips "G".
- 3—Retighten screw "E".

To Adjust "H" Switch

- 1—Loosen screw "E".
- 2—Turn screw "D" until cam roller trips "H".
- 3—Retighten screw "E".

LUBRICATION

This limit switch was lubricated at the factory and should not require lubrication for the life of the switch.

Nominal Input Shaft to Cam Ratio	Turns of Input Shaft		
	Maximum	Minimum	To Reset
5:1	4	1/8	1/16
10:1	8-1/2	1/4	1/8
20:1	17	1/2	1/4
30:1	26	1	3/8
40:1	35	1	1/2
60:1	53	2	3/4
80:1	72	2-1/2	1
120:1	108	3	1-1/2

RENEWAL PARTS

When ordering Renewal Parts give this Form No. 63, Item No., Description, Quantity, Part No. and the complete number stamped on the label.

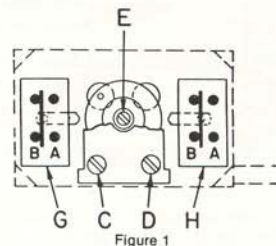
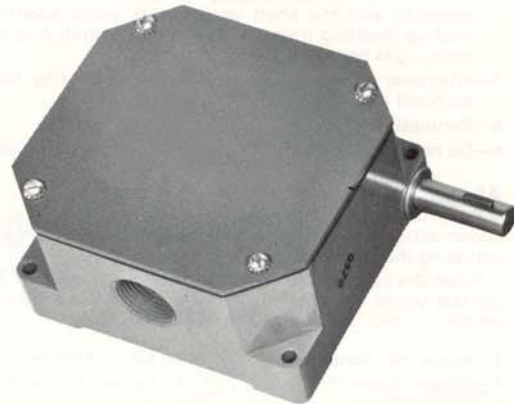
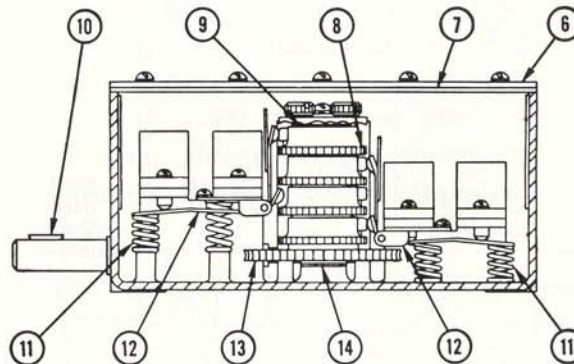
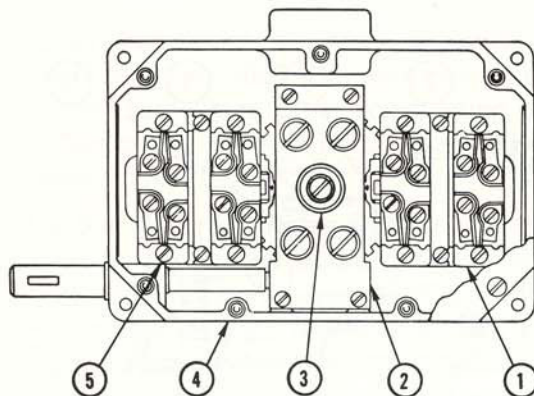

Figure 1



4 Circuit Type K Rotary Limit Switch



DESCRIPTION AND OPERATION

This is a four circuit rotary limit switch. It is designed to control the limits of travel and to co-ordinate additional or sequence operations of rotating reversing equipment. This limit switch provides adjustable trip positions of the switch units.

The limit switch input shaft is connected to a worm gear. Four independently adjustable self lubricating nylon roller cams are concentrically mounted on the worm gear. These adjustable cams actuate the single pole double throw precision limit switch units.

INSTALLATION

This limit switch may be mounted in any convenient position. When installed this limit switch will provide long life with a minimum amount of service maintenance.

The following recommendations will prove helpful.

- 1—Install the limit switch so that the shaft load will not exceed five pounds.
- 2—A flexible coupling is recommended for all installations other than gear drives.
- 3—Couplings should be employed in a manner that results in a minimum of thrust loading of the shaft. If switches are mounted with the shaft up or down, some additional thrust loading resulting from the weight of the shaft plus a very light coupling is permissible.
- 4—Whenever possible, a separate support bearing for the drive sprocket should be used.
- 5—Permissible speed of the input shaft 2000 R.P.M.
- 6—Do not hammer couplings, gear, etc., on to the input shaft.

ADJUSTMENT

Refer to figure 1. The electrical switch units G, H, L and M are shown with the contact positions assumed when the cams are not actuating the switch units.

When the cam rotates and actuates the switch, the "B" (closed) contact opens and the "A" (open) contact closes. Each electrical switch unit has its independent adjustable cam.

To Adjust "G" Switch

- 1—Loosen screw "E".
- 2—Turn screw "C" until cam roller trips "G".
- 3—Retighten screw "E".

To Adjust "L" Switch

- 1—Loosen screw "E".
- 2—Turn screw "J" until cam roller trips "L".
- 3—Retighten screw "E".

To Adjust "H" Switch

- 1—Loosen screw "E".
- 2—Turn screw "D" until cam roller trips "H".
- 3—Retighten screw "E".

To Adjust "M" Switch

- 1—Loosen screw "E".
- 2—Turn screw "K" until cam roller trips "M".
- 3—Retighten screw "E".

LUBRICATION

This limit switch was lubricated at the factory and should not require lubrication for the life of the switch.

Nominal Input Shaft to Cam Ratio	Turns of Input Shaft		
	Maximum	Minimum	To Reset
5:1	4	1/8	1/16
10:1	8-1/2	1/4	1/8
20:1	17	1/2	1/4
30:1	26	1	3/8
40:1	35	1	1/2
60:1	53	2	3/4
80:1	72	2-1/2	1
120:1	108	3	1-1/2

RENEWAL PARTS

When ordering Renewal Parts give this Form No. 66, Item No., Description, Quantity, Part No., and the complete number stamped on the label.

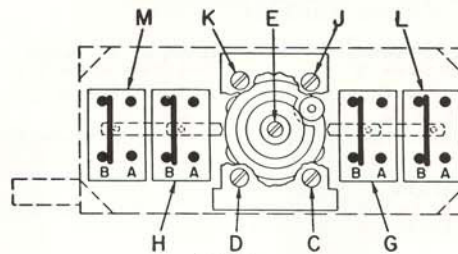
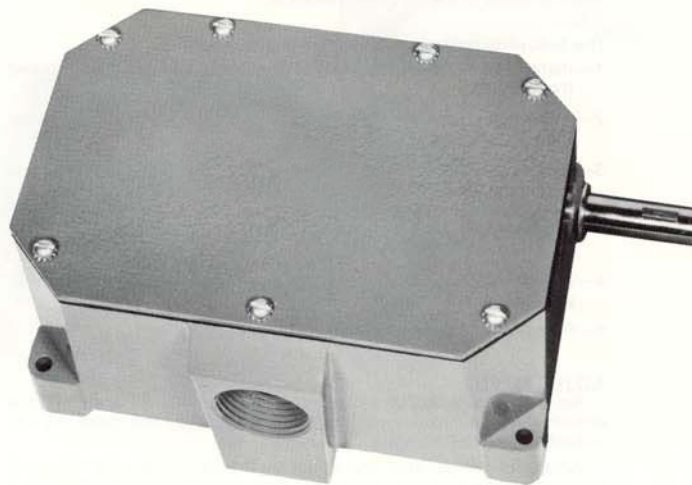

Figure 1