

ActionJac Electric Cylinders can be supplied with industrial quality brake motors. Brake motors include a spring actuated, electrically released braking mechanism which will hold a load when the power is off. In normal operation, power is applied and removed to the motor windings and brake release simultaneously.

If it is desired to operate the brake separately, as when used with a speed control, the brake needs to be wired

externally. Standard for Reliance motors, special order for Baldor motors.

Standard motors are: 3 phase, 208-230 / 460 VAC, 60 Hz. 1725 rpm. Also available are single phase motors at: 115 / 230 VAC, 60 Hz. 1725 rpm. All motors are rated for continuous duty. Note: for inverter duty motors or additional options, contact Nook Industries.

BALDOR: INTERNALLY WIRED BRAKE MOTOR ORDER CODE

MOTOR HP	STD. MOTOR 208-230/460 3PH	SINGLE PHASE 115/230 1PH	XT EXTRA TUFF 208-230/460 3PH	WASH DOWN MOTOR IP55 208-230/460 3PH	EXPLOSION PROOF • DIVISION 1 • CLASS 1,2 • GROUP F & G • 208/230/460 • 3PH
1/4	02BT	02BS	02BX	02BW	02BE
1/3	03BT	03BS	03BX	03BW	03BE
1/2	05BT	05BS	05BX	05BW	05BE
3/4	07BT	07BS	07BX	07BW	07BE
1	10BT	10BS	10BX	10BW	10BE
1-1/2	15BT	-	15BX	15BW	15BE
2	20BT	-	20BX	20BW	20BE
3	30BT	-	30BX	30BW	30BE
5	50BT	-	50BX	50BW	50BE
7-1/2	75BT	-	75BX	75BW	-

RELIANCE: EXTERNALLY WIRED BRAKE MOTOR ORDER CODE

MOTOR HP	STD. MOTOR 208-230/460 3PH	SINGLE PHASE 115/230 1PH	XT EXTRA TUFF 208-230/460 3PH	WASH DOWN MOTOR IP55 208-230/460 3PH	EXPLOSION PROOF • DIVISION 1 • CLASS 1,2 • GROUP F & G • 208/230/460 • 3PH
1/4	02RT	02RS	02RX*	02RW*	02RE*
1/3	03RT	03RS	03RX*	03RW*	03RE*
1/2	05RT	05RS	05RX*	05RW	05RE
3/4	07RT	07RS	07RX*	07RW	07RE
1	10RT	10RS	10RX*	10RW	10RE
1-1/2	15RT	-	15RX*	15RW	15RE
2	20RT	-	20RX*	20RW	20RE
3	30RT	-	30RX*	30RW*	30RE
5	50RT	-	50RX*	50RW*	50RE
7-1/2	75RT*	-	75RX*	75RW*	75RE*

*specify minimum quantity required

BRAKE MOTOR WIRING

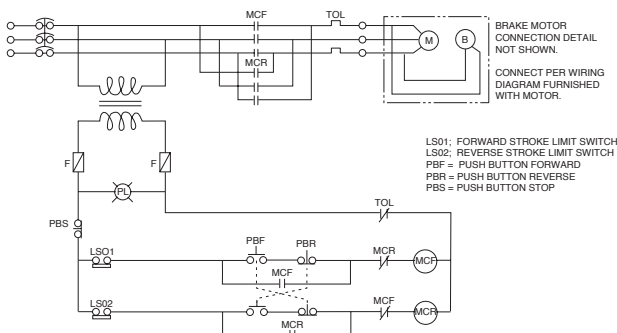

A typical wiring drawing is shown here, for a three-phase brake motor. This example is for reference only, the correct wiring will vary for each application.

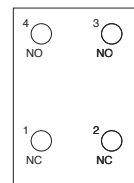
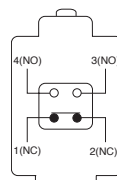

CONTACT CONFIGURATION

TERMINAL ARRANGEMENT